

Severe Duty Overhead Self-Cleaning Electromagnet

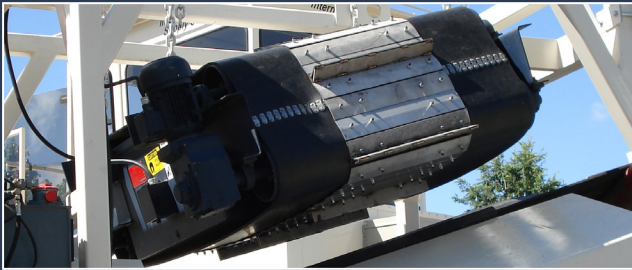

- ◇ Dings 'Durabelt'— stainless steel pads and cleats protect the entire impact area and are easy to replace in the field.
- ◇ Stainless steel bottom and center wear plate
- ◇ Balanced magnetic circuit for maximum efficiency and equal distribution of length, width and depth of magnetic circuit



Dings Severe Duty Self-Cleaning Electromagnet

The Severe Duty Model is specifically designed for tough applications. It is built to withstand the harshest environments and comes equipped with a Dings 'Durabelt' that prevents the underlying rubber belt from being pierced by sharp tramp metal, a heavy duty drive assembly, lagging on the drive pulley and reinforced suspension/mounting hardware.

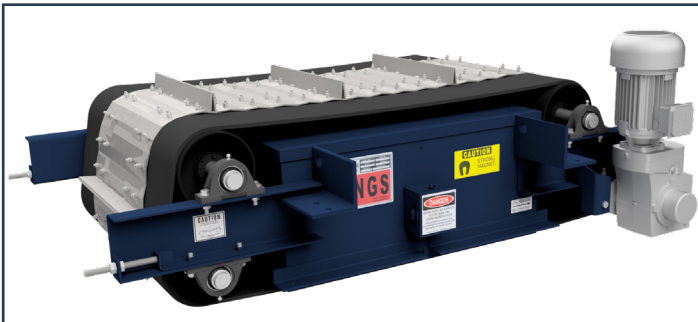

Anodized Aluminum Strap Coils

Dings electromagnetic coils are wound with an anodized aluminum strap— an exclusive design that generates more magnetism than any other on the market and exceeds Class H insulation rating! This design outlasts and out-performs copper wire with polymer insulation or bare aluminum with Nomex® insulation.

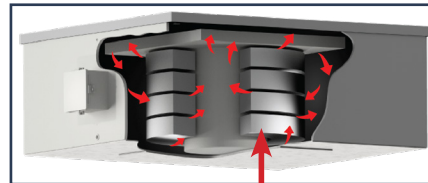

Oil Flow =  Anodized Aluminum Strap



20-Year Warranty on Coil Burnout

Dings Electromagnetic Coils

- ◇ No insulation is needed with anodized aluminum straps - eliminating the major cause of coil failure (insulation breakdown)
- ◇ More magnetism and separating power - generated by extra turns
- ◇ Each turn is exposed to cooling oil - assuring a stronger, more efficient magnet
- ◇ Eliminates the need for external oil expansion pipes or tanks that require maintenance and can be damaged

Dings Electromagnetic Rectifiers



- ◇ Maintenance-free
- ◇ Overload capacity for short infrequent periods
- ◇ Corrosion protection in extreme environments

Note: All electromagnets require a DC power supply. Rectifiers converts alternating current (AC) from your local power source to the necessary direct current (DC) needed by electromagnets.

Inline Mounting Position

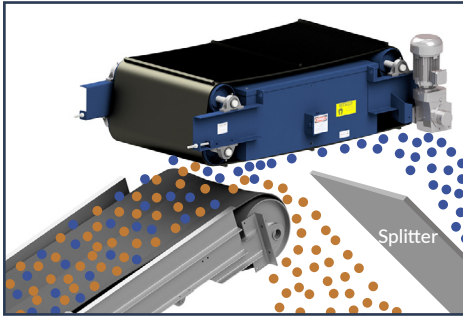

Crossbelt Over the Head Pulley

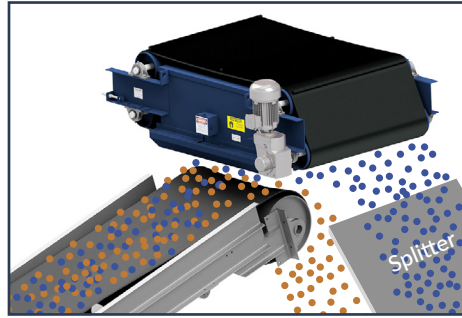

Crossbelt Over the Conveyor Belt

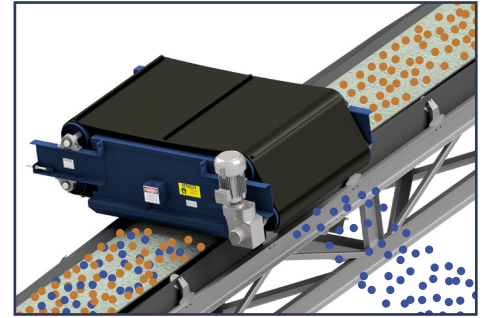

Non-Magnetic Material ■ Magnetic Material ■

Inline orientation is a more efficient mounting position than Crossbelt over the conveyor belt. With an inline mounted magnet, ferrous metal is liberated from the material as it is discharged from the conveyor making it easier to separate. Inline orientation sometimes permits the use of a smaller more economic magnet compared to cross-belt over the conveyor belt because the suspension height is reduced.

Cross-belt over the head pulley orientation is a more efficient option than mounting over the belt. One reason for this is the conveyor belt flattens as it reaches the pulley allowing for a reduced suspension height. Another is as the material leaves the conveyor it becomes airborne liberating the tramp metal and making it easier to separate. This orientation may permit the use of a smaller more economic magnet.

In a cross-belt over the conveyor belt mounting position the magnet is installed at a right angle to the travel direction of the material on the belt. Tramp metal is collected by the magnet and discharged by the magnet's self-cleaning belt into a collection bin along side the conveyor. This orientation is commonly used when the magnet is being installed on an existing conveyor.

More Dings Company Magnetic Separation Equipment

Magnetic Head Pulley

Available in 3 different strength series



MRF (Material Recovery Facility) Overhead Self-Cleaning Electromagnet

3" high cleats



Overhead Self-Cleaning Permanent Magnet

Lifetime warranty on magnetism

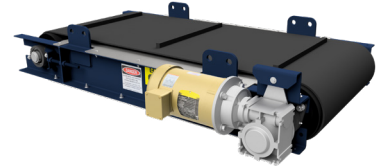

Eddy Current Separator

Separate non-ferrous metal

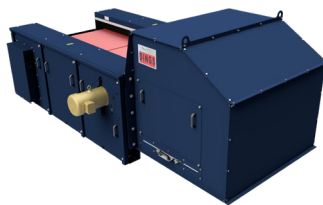

Deep Draw Drum Magnet



ver.1/25

Engineering Driven - Customer Service Focused

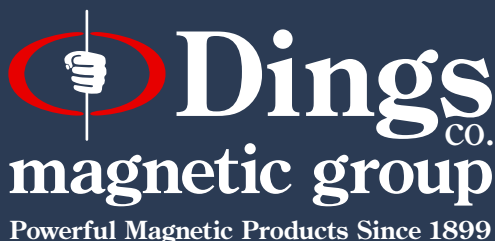

Dings Company Magnetic Group engineering and sales staff work together from our Milwaukee, WI factory to provide outstanding customer service from experts in magnetic separation. First, we listen to our customers to gain an understanding of their needs. Then we apply our experience in their trade to provide magnetic separation equipment that is sized and positioned for the best possible performance in their specific application.