

Magnetic Separation for Wood & Biomass Applications



Your Equipment is Designed to Cut, Shred and Process Wood and Other Biomass – Not Metal.

Dings Company Magnetic Separators Remove Ferrous Metal Before It Can Cause Damage to Your Processing Equipment While Improving Your Products Purity.

- ◇ When metal is prevalent self-cleaning overhead magnets will separate and automatically transfer ferrous metal to collection bins.
- ◇ When metal is rare but catastrophic stationary overhead magnets will economically separate ferrous metal and hold it until it is convenient to cut the power to an electro magnet or manually clean a permanent magnet.
- ◇ Magnetic pulleys will serve to separate ferrous metal as material is being discharged from your feeding conveyor.

Overhead Stationary Permanent Magnet

- ◇ Unique construction - the best ratio of field strength produced per size & weight of any in the industry.
- ◇ Magnet housing filled with Ceramic VIII magnet material.
- ◇ Full stainless steel bottom plate
- ◇ Non-magnetic stainless steel construction that prevents collection of ferrous metals on the magnet frame.

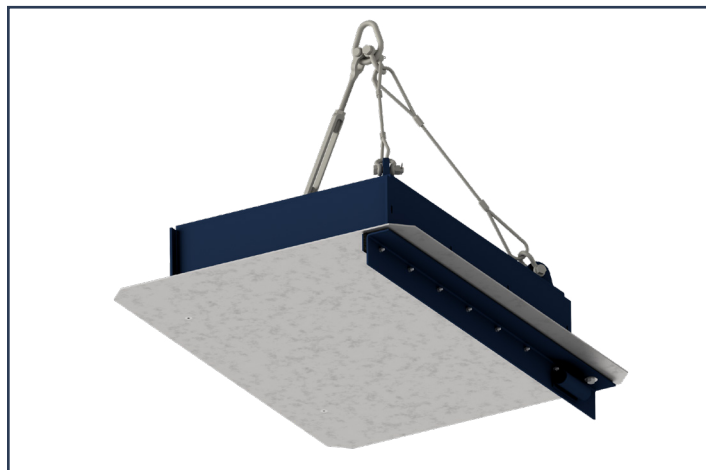

Optional sweep arm attachment for Stationary Model allows easier tramp metal removal

Dings Stationary Permanent Magnet

Virtually maintenance-free with no moving parts Ferrous metal is pulled out of the material stream and held in place until manually removed. Designed for easy installation, this model comes with a 3-point sling suspension system that includes two cables and one turnbuckle connected to a bull ring. Adjustment of suspension angle is easy. There is no measuring, shortening, lengthening or cutting of cable required. Stationary Permanent Magnets can be the most economical method of removing tramp metal when it is rare but must be removed.

Dings Flux Control (DFC) Circuit

Dings Flux Control (DFC) Circuit design eliminates internal leakage between magnetic poles and improves separating performance. Other 'conventional' magnetic circuits contain air or filler material between the magnetic poles; this allows flux (magnetism) to escape (leak out) and be wasted. In Dings DFC design - blocking magnets are strategically positioned in the spaces between the magnetic poles. These redirect the flux outward, into your product, converting the wasted flux into working force - making the magnet more efficient.

Dings DFC Design improves the overall performance of the magnet in 3 ways

- ◇ The magnetic field is stronger
- ◇ The magnetic field extends deeper
- ◇ The magnetic field pattern is more uniform



On Magnetism
for all Permanent
Magnets

Conventional Magnetic Circuit With "filler" between the poles

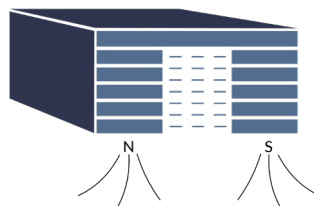

--- Indicates flux leakage in airspace

Dings Magnetic Circuit with blocking magnets between the poles

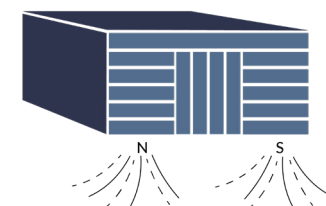

--- Indicates leakage converted to work force



Overhead Self-Cleaning Permanent Magnet

- ◇ Unique construction - the best ratio of field strength produced per size & weight of any in the industry.
- ◇ Magnet housing filled with Ceramic VIII magnet material.
- ◇ Multi-ply rubber belt with hot vulcanized 1" cleats for superior adhesion
- ◇ Non-magnetic stainless steel construction that prevents collection of ferrous metals on the magnet frame.

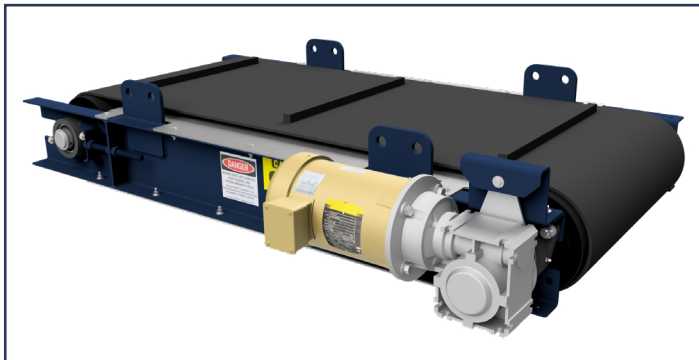

Dings Self-Cleaning Permanent Magnet

Dings Self-Cleaning Models' belt continuously travels across the face of the magnet to automatically discharge tramp iron. This save time and labor costs.

The Self Cleaning Permanent Model comes equipped with a standard multi-ply rubber belt with 1 inch vulcanized cleats.

Inline Mounting Position

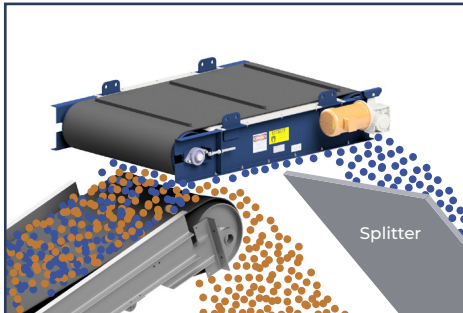

Crossbelt Over Head Pulley

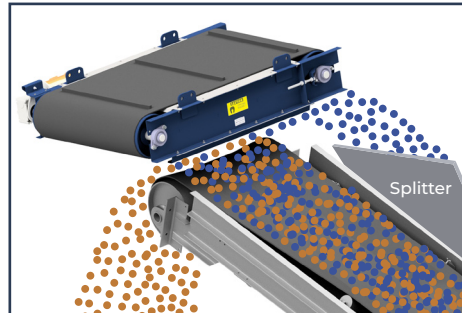

Crossbelt Over Conveyor Belt

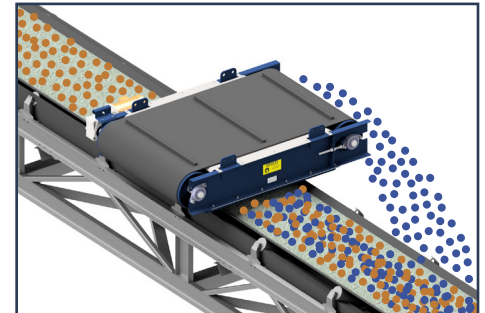

Non-Magnetic Material ■ Magnetic Material ■

Inline orientation is a more efficient mounting position than Crossbelt over the conveyor belt. With an inline mounted magnet, ferrous metal is liberated from the material as it is discharged from the conveyor making it easier to separate. Inline orientation sometimes permits the use of a smaller more economic magnet compared to cross-belt over the conveyor belt because the suspension height is reduced.

Cross-belt over the head pulley orientation is a more efficient option than mounting over the belt. One reason for this is the conveyor belt flattens as it reaches the pulley allowing for a reduced suspension height. Another is as the material leaves the conveyor it becomes airborne liberating the tramp metal and making it easier to separate. This orientation may permit the use of a smaller more economic magnet.

In a cross-belt over the conveyor belt mounting position the magnet is installed at a right angle to the travel direction of the material on the belt. Tramp metal is collected by the magnet and discharged by the magnet's self-cleaning belt into a collection bin along side the conveyor. This orientation is commonly used when the magnet is being installed on an existing conveyor.



Magnetic Head Pulley

- ◇ Dings Flux Control (DFC) Circuit on our DFC Ultra Model
- ◇ Automatic and continuous separation
- ◇ Easily integrated into existing processing systems
- ◇ Magnet assembly filled with Ceramic VIII magnet material

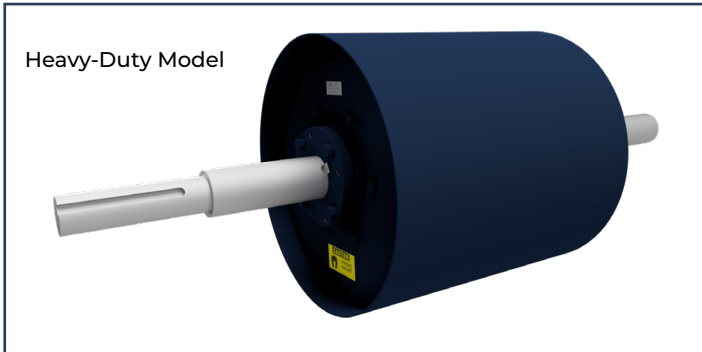

Dings Magnetic Head Pulleys

Non-electric, self-cleaning magnetic separators. They operate as head pulleys on conveyors to separate tramp iron and iron impurities from materials conveyed in bulk form. They are designed for machinery protection and product purification. Our magnetic head pulley's magnetism is produced by an internal ceramic magnet assembly that is enclosed with a nonmagnetic stainless steel shell. Magnetic Head Pulleys come shipped ready to install!

Head Pulley Material Trajectory

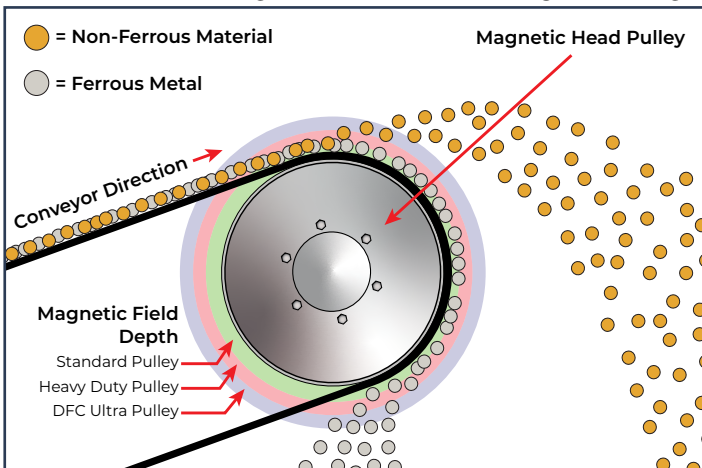

Magnetic Head Pulley Sizes

Dings Standard	8", 12" 15" 18" 20" & 24" Diameters
Dings Heavy Duty	12", 15", 18", 20", 24", 30", 36" & 42" Diameters
Dings DFC Ultra	12", 15", 18", 20", 24", 30", 36" & 42" Diameters



When Magnets Aren't Enough...

SurroundScan Protector Metal Detectors

- ◇ Detects Ferrous, Non-Ferrous & Stainless Steel
- ◇ Engineered to Endure Tough Applications the Others Simply Cannot.
- ◇ Removable end plate facilitates easy installation without removing conveyor belt.
- ◇ Protects precision processing equipment



a Dings co. Magnetic Group sister company.