



Engineering Driven
Customer Service Focused

Providing Engineered
Magnetic Solutions for **125** Years

dingsmagnets.com | magsales@dingsco.com
(414)672-7830

Magnetic Separation for Aggregate & Mining Applications



Call us for Expert Support of Dings Co. Equipment - Regardless of its Age



Dings magnetic group

Overhead Magnets Electro and Permanent

Aggregate & Mining Applications

Dings overhead magnets provide the industry's best performance and the durability that's required to prevent damage to processing equipment and costly down-time

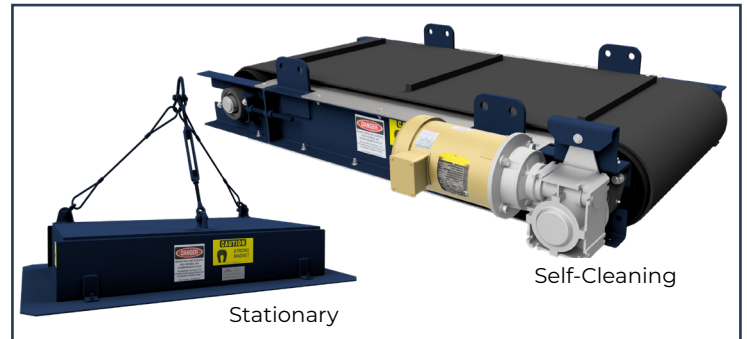
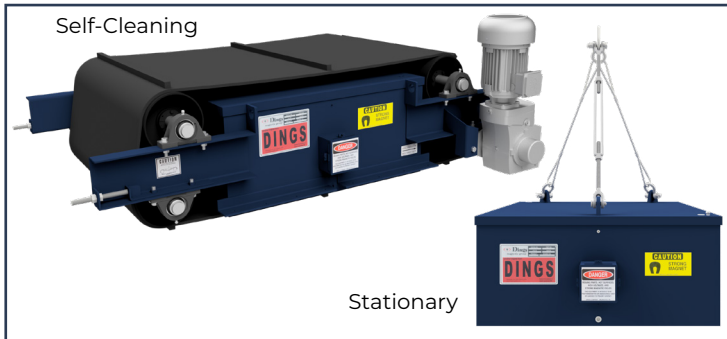

Dings Electromagnets

- ◇ Balanced Magnetic Circuit for maximum efficiency and equal distribution of length, width and depth of magnetic circuit
- ◇ Multi-ply rubber belt with hot vulcanized 1" cleats for superior adhesion (Self-cleaning models)
- ◇ Severe Duty Model with stainless steel Durabelt pads and cleats to protect underlying rubber belt (Self-cleaning)
- ◇ Stationary Model is virtually maintenance-free with no moving parts. (except cooling oil changes as needed)
- ◇ Stainless steel bottom and center wear plate provides extra protection in the main impact area

Dings Permanent Magnets

- ◇ No power supply needed for magnet (Stationary Model)
- ◇ Maintenance-free design (Stationary Model)
- ◇ Unique construction - the best ratio of field strength produced per size & weight of any in the industry!
- ◇ Magnet housing filled with Ceramic VIII magnet material
- ◇ Full stainless steel bottom plate
- ◇ 8 point mounting lugs (self-cleaning models)

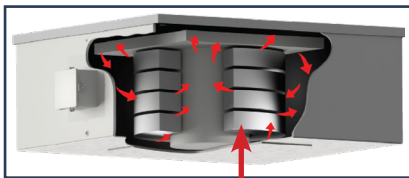

Oil Flow = Anodized Aluminum Strap



20-Year Warranty on Coil Burnout

Conventional Magnetic Circuit With "filler" between the poles

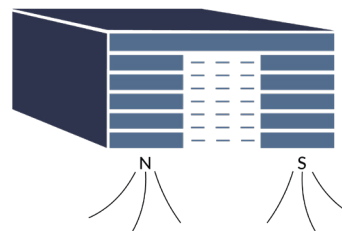

--- Indicates flux leakage in airspace

Dings Magnetic Circuit with blocking magnets between the poles

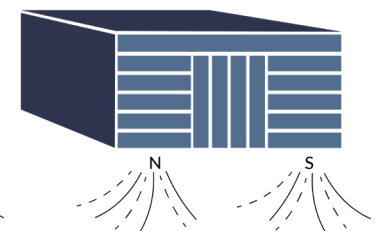

--- Indicates leakage converted to work force

Dings Electromagnetic Coils

- ◇ No insulation is needed with anodized aluminum - eliminating the major cause of coil failure (insulation breakdown)
- ◇ More magnetism and separating power - generated by extra turns
- ◇ Each turn is exposed to oil-cooling - assuring a stronger, more efficient magnet
- ◇ Eliminates the need for external oil expansion pipes or tanks that require maintenance and can be damaged

Dings DFC Design improves the overall performance of the magnet in 3 ways

- ◇ The magnetic field is stronger
- ◇ The magnetic field extends deeper
- ◇ The magnetic field pattern is more uniform



On Magnetism for Permanent Magnets

Call us for Expert Support of Dings Co. Equipment - Regardless of its Age



Dings magnetic group

Magnetic Head Pulleys

No Cost Operation

- ◇ Dings Flux Control Circuit on our DFC Ultra Model
- ◇ Automatic and continuous separation
- ◇ Easily integrated into existing processing systems
- ◇ Magnet assembly filled with Ceramic VIII magnet material
- ◇ Type 304 nonmagnetic stainless steel shell

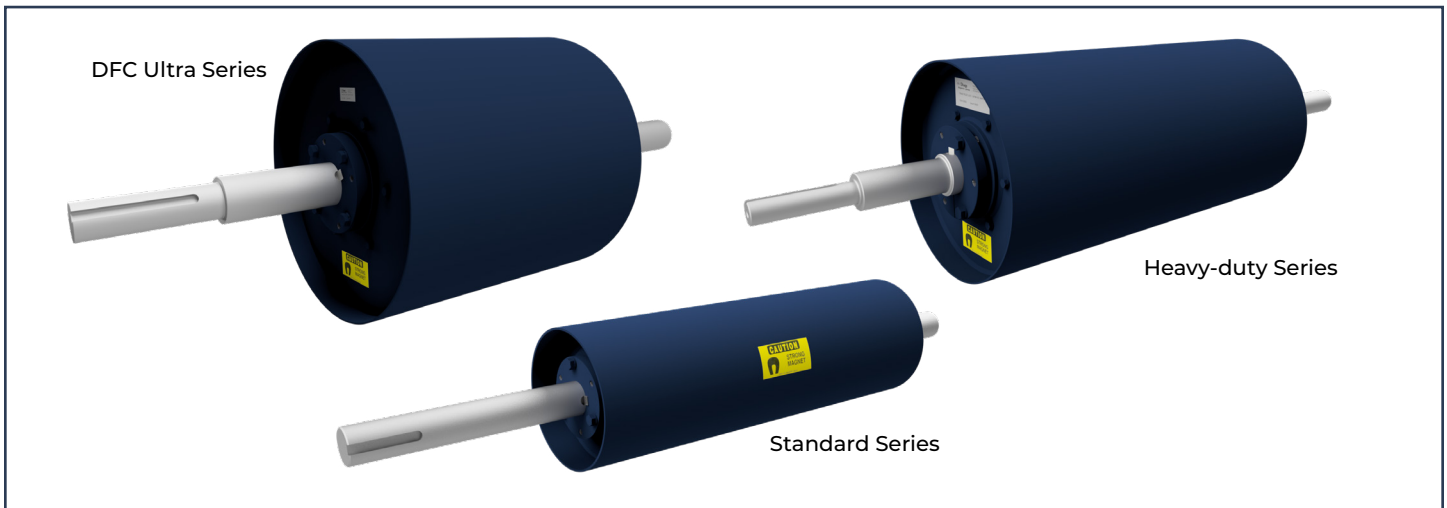

Magnetic Head Pulleys

Are non-electric, self-cleaning magnetic separators. They operate as head pulleys on conveyors to separate tramp iron and iron impurities from materials conveyed in bulk form. They are designed for machinery protection and product purification. Our magnetic head pulley's magnetism is produced by an internal ceramic magnet assembly that is enclosed with a nonmagnetic stainless steel shell.

Magnetic Head Pulley Operation & Strength

Since every application has its own specific needs regarding the magnetic depth of field required, Dings Company Magnetic Group is the only company to offer you three different magnetic strengths.

Magnetic Head Pulley Material Trajectory

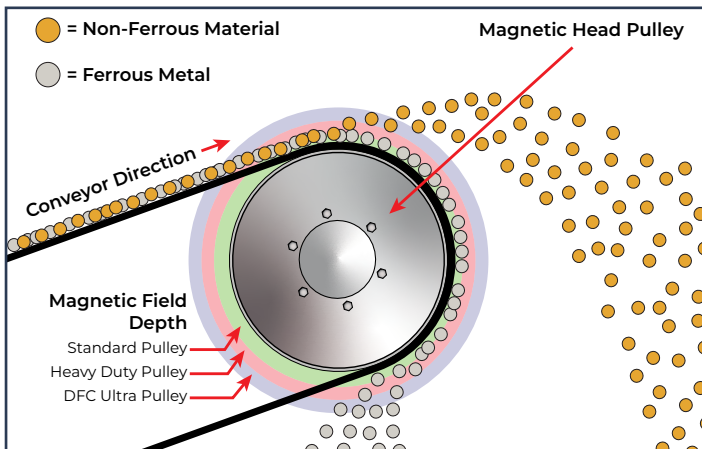

Dings Standard
8", 12" 15" 18" 20" & 24"
Diameters

Dings Heavy Duty
12", 15", 18", 20", 24", 30", 36" & 42"
Diameters

Dings DFC Ultra
12", 15", 18", 20", 24", 30", 36" & 42"
Diameters

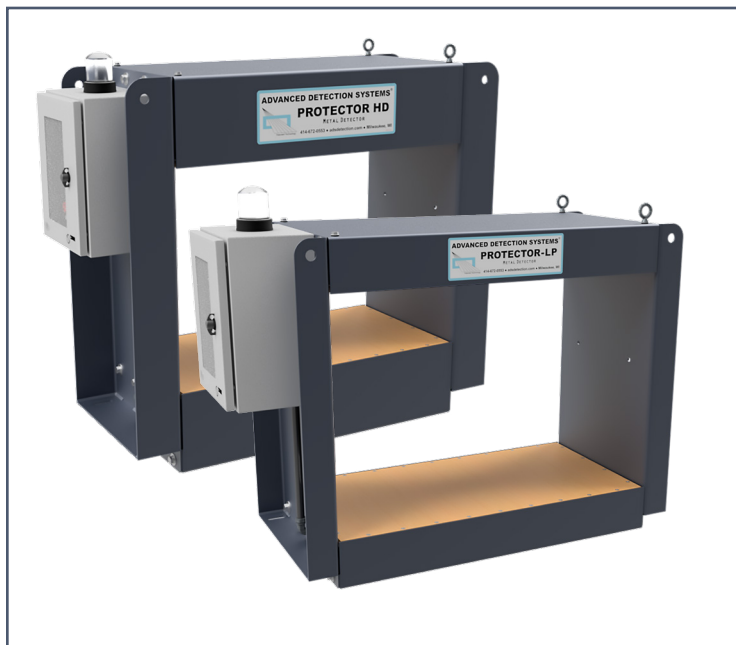
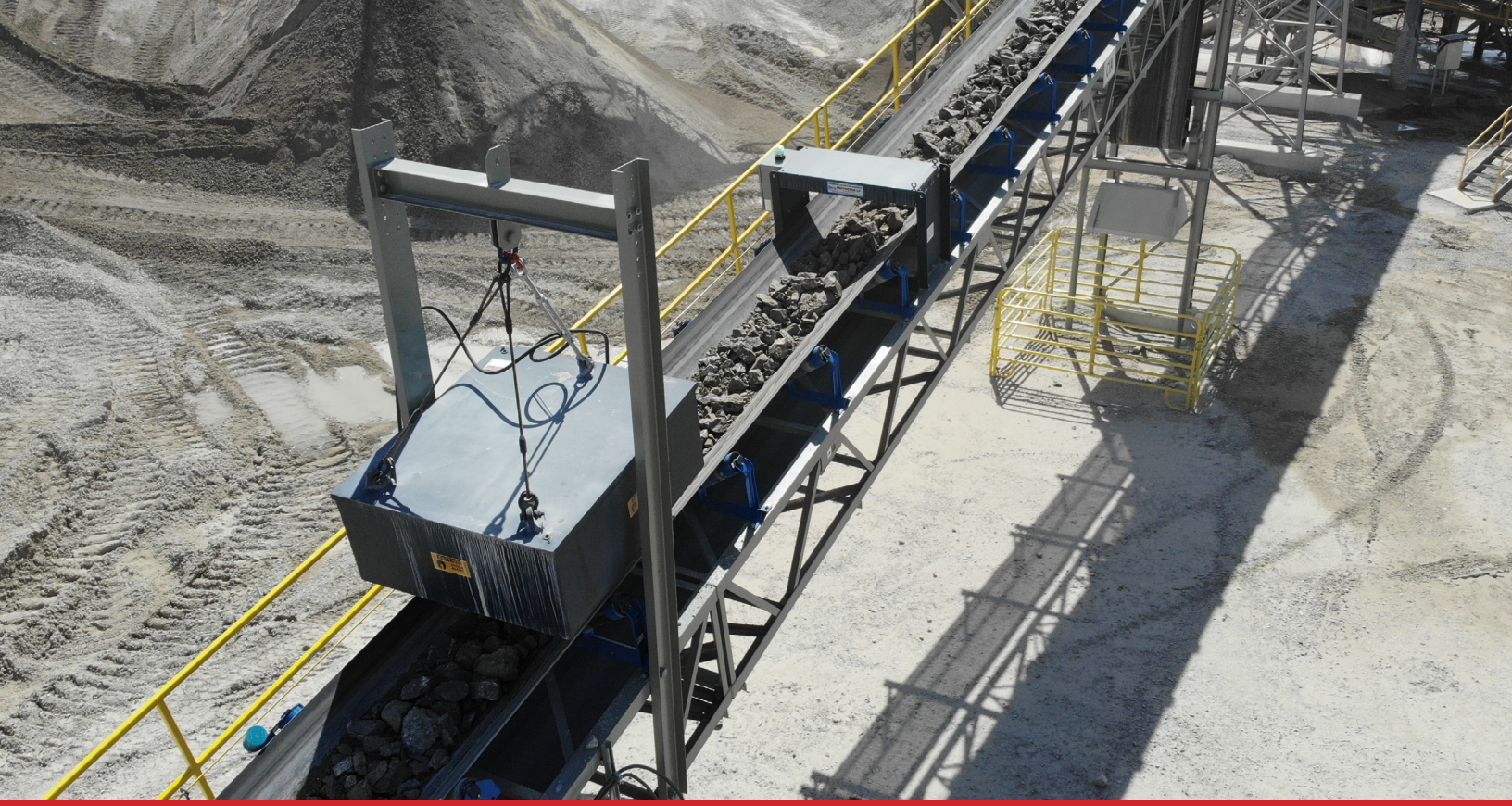

A Sister Company of
Dings co. Magnetic
Group

When Magnets Aren't Enough Use SurroundScan Protector Series Metal Detectors from ADS

Advanced Detection Systems' Protector Metal Detectors are designed to detect ferrous, non-ferrous and stainless-steel metal in bulk material ensuring product purity and protecting processing equipment. Heavy-duty carbon steel construction and engineering allow our metal detectors to withstand tough applications and harsh environments others simply cannot. Our metal detectors are offered as a complete system with splice sensor and metal marking accessories.

ver. 1-25

Engineering Driven - Customer Service Focused



Dings Company Magnetic Group engineering and sales staff work together from our Milwaukee, WI factory to provide outstanding customer service from experts in magnetic separation. We listen to our customers to gain an understanding of their needs and apply our experience in their trade to provide magnetic separation equipment that is sized and positioned for the best possible performance in their specific application.