

## Magnetic Head Pulley

- ◇ Dings Flux Control (DFC) Circuit on our DFC Ultra Model
- ◇ Automatic and continuous separation
- ◇ Easily integrated into existing processing systems
- ◇ Magnet assembly filled with Ceramic VIII magnet material
- ◇ Type 304 nonmagnetic stainless steel shell
- ◇ NO COST operation

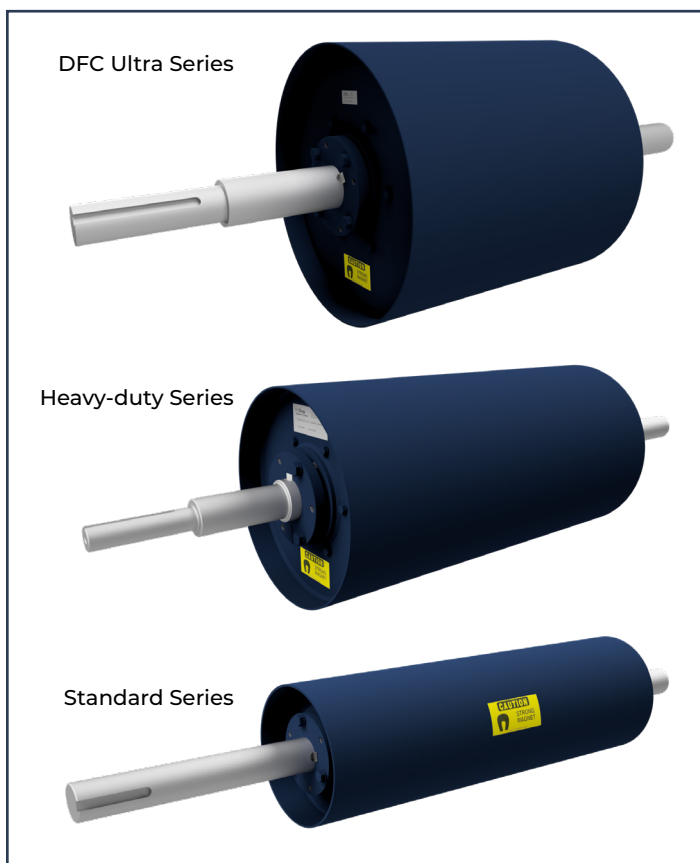

**Dings Magnetic Head Pulleys** are non-electric, self-cleaning magnetic separators. They operate as head pulleys on conveyors to separate tramp iron and iron impurities from materials conveyed in bulk form. They are designed for machinery protection and product purification. Our magnetic head pulley's magnetism is produced by an internal ceramic magnet assembly that is enclosed with a nonmagnetic stainless steel shell. Magnetic Head Pulleys come shipped ready to install!

### Dings Flux Control (DFC) Circuit

Dings Flux Control (DFC) Circuit design eliminates internal leakage between magnetic poles and improves separating performance. Other 'conventional' magnetic circuits contain air or filler material between the magnetic poles; this allows flux (magnetism) to escape (leak out) and be wasted. In Dings DFC design - blocking magnets are strategically positioned in the spaces between the magnetic poles. These redirect the flux outward, into your product, converting the wasted flux into working force - making the magnet more efficient.

### Dings DFC Design improves the overall performance of the magnet in 3 ways

- ◇ The magnetic field is stronger
- ◇ The magnetic field extends deeper
- ◇ The magnetic field pattern is more uniform



On Magnetism  
for all Permanent  
Magnets

Conventional Magnetic Circuit  
With "filler" between the poles

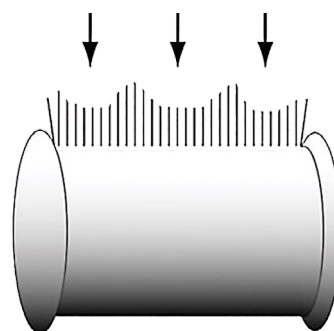

leakage

Dings Magnetic Circuit  
with blocking magnets  
between the poles

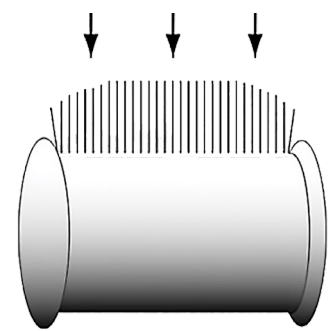

No leakage

## Magnetic Head Pulley Material Trajectory

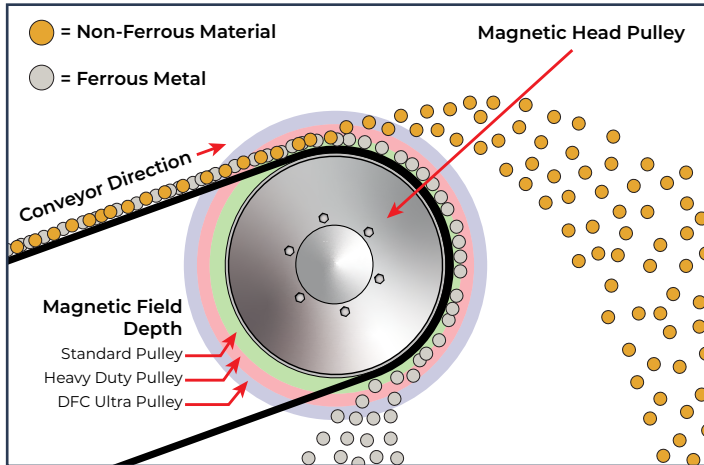

## Magnetic Head Pulley Operation & Strength

Since every application has its own specific needs regarding the magnetic depth of field required, Dings Company Magnetic Group is the only company to offer you three different magnetic strengths.

### Dings Standard

8", 12" 15" 18" 20" & 24"  
Diameters

### Dings Heavy Duty

12", 15", 18", 20", 24", 30", 36" & 42"  
Diameters

### Dings DFC Ultra

12", 15", 18", 20", 24", 30", 36" & 42"  
Diameters

## More Dings Company Magnetic Separation Equipment

### Overhead Stationary Permanent Magnet

Lifetime warranty on magnetism



### Overhead Self-Cleaning Permanent Magnet

Lifetime warranty on magnetism

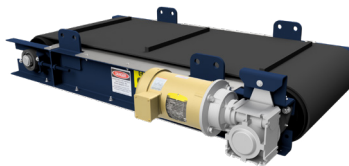

### Eddy Current Separator

Separate non-ferrous metal



### Overhead Self-Cleaning Electromagnet



### MRF (Material Recovery Facility) Overhead Self-Cleaning Electromagnet

3" high cleats



### Deep Draw Drum Magnet



ver. 1/25

## Engineering Driven - Customer Service Focused



Dings Company Magnetic Group engineering and sales staff work together from our Milwaukee, WI factory to provide outstanding customer service from experts in magnetic separation. First, we listen to our customers to gain an understanding of their needs. Then we apply our experience in their trade to provide magnetic separation equipment that is sized and positioned for the best possible performance in their specific application.