



Powerful Magnetic Products Since 1899

Engineering Driven
Customer Service Focused

dingsmagnets.com | magsales@dingsco.com
(414)672-7830

Eccentric
Eddy Current
Separators

- ◇ Recover Non-Ferrous to Generate Income
- ◇ Improve the Purity of Your Product Stream.

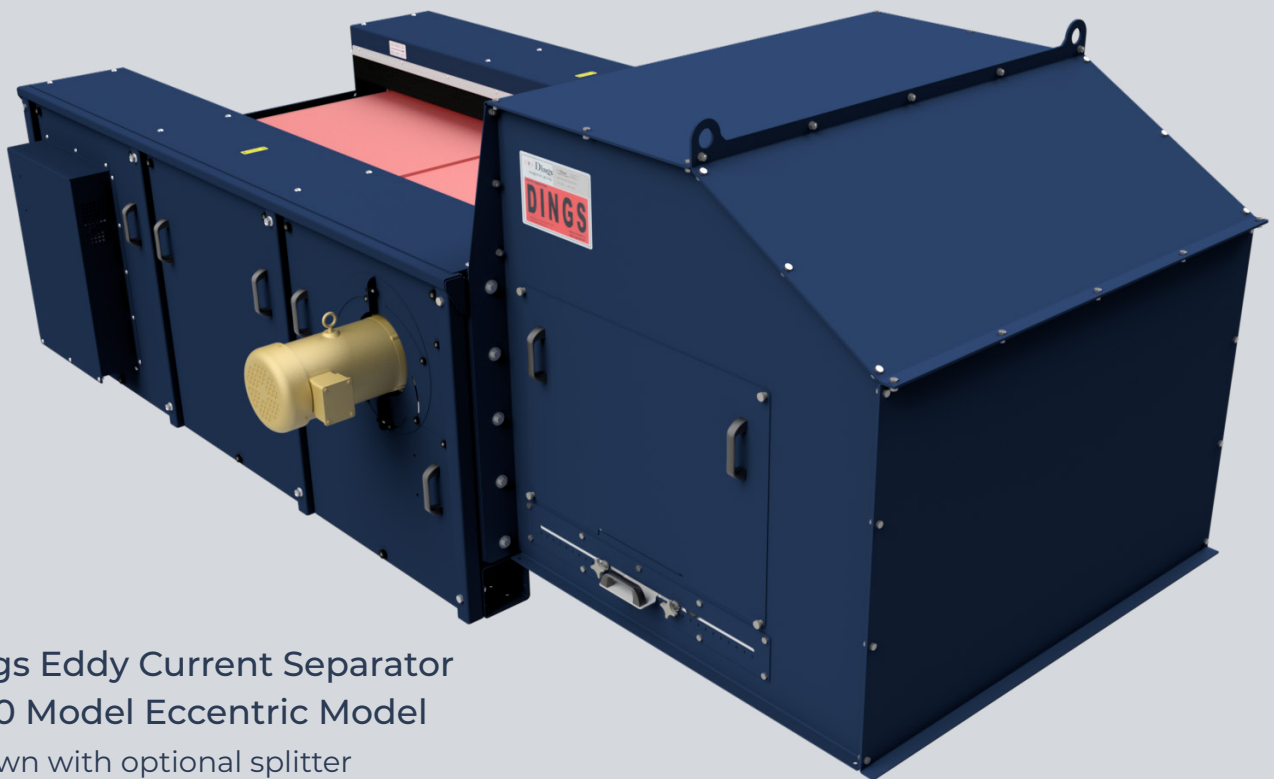

Dings Eddy Current Separator
9900 Model Eccentric Model

*Shown with optional splitter

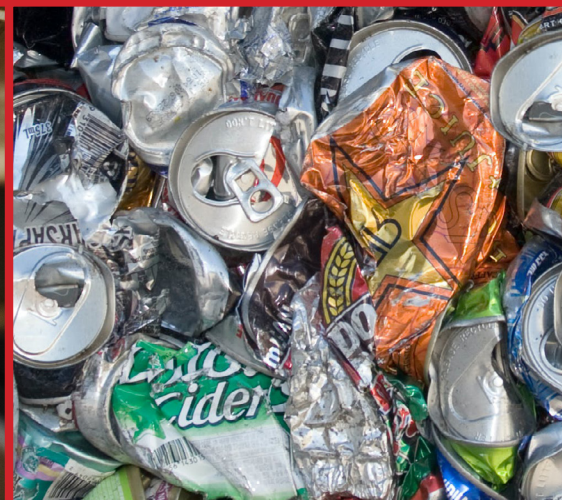

Call us for Expert Support of Dings Co. Equipment - Regardless of its Age

Eddy Current Separator: Eccentric Design

Separate aluminum, die-cast metal or copper from non-metallic material. Dings continues its tradition of innovative design offering new features that optimize separation and simplify maintenance. Our new Eddy Current Separator is engineered to withstand severe outdoor environments and dirty, dusty surroundings found at many job sites.

- ◇ Polyurethane wear resistant belt with corrugated side walls for material containment and long life.
- ◇ Belt motor moves with take-up assembly for easy tracking and adjustment
- ◇ Easy to remove panels gives access to bearing and belt reduce maintenance time.
- ◇ Access Panels also make endless belt easily replaceable.
- ◇ Oversized, high speed rotor bearings & shaft
- ◇ Stainless steel rotor shell with fiberglass wear shield.

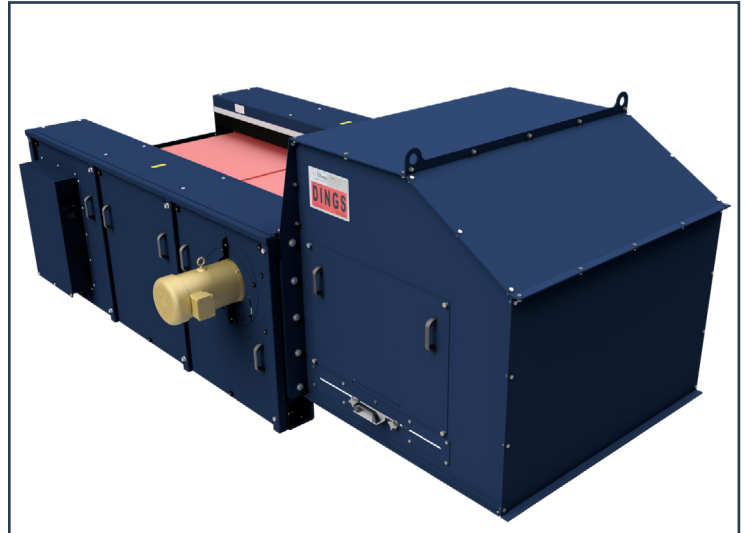
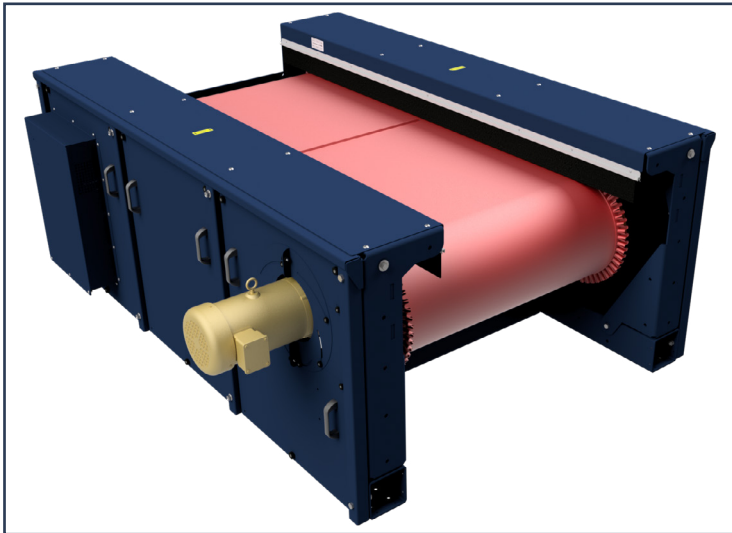

Dings Eddy Current Eccentric Design

Ideal for separating non-ferrous from fractional sizes up to the size of aluminum cans from paper and plastic product streams. The off center "eccentric" magnet design of the rotor allows ferrous metal that made it past the upstream magnetic separator to be released from the belt as it leaves the magnetic area of the outer rotor shell. This reduces the likelihood that ferrous metal will cling to and damage the belt and shell, extending rotor life.

- ◇ Rare earth magnets provide high strength & long life.
- ◇ Heavy Duty Steel Cantilevered Frame makes endless belt replacement simple, 15 minutes or less.
- ◇ Easy to remove panels give access to bearings and belt reducing maintenance time.

Eddy Current Separator Options

- ◇ Standard & Non-Standard Variable Speed Belt & Rotor Control Panels
- ◇ Fixed Speed Control Panel; UL/CSA Control Panels
- ◇ Belt Tracking Sensor
- ◇ Splitter Assembly
- ◇ Custom Lengths & Heights

9900 Eccentric Model

Pulley Diameter: 16" (8" Interior Magnetic Rotor)
Belt Width: 36", 48" or 60"

Applications: Ideal for separating non-ferrous from fractional sizes up to the size of aluminum cans from paper and plastic product streams.

Dings Eddy Current Operation

Material is fed onto the conveyor belt of the eddy current separator, which moves it across the magnetic rotor where separation occurs. The two streams of material discharge into a housing. The housing has a splitter to divide the non-ferrous metal from the nonmetallic material (such as: paper, plastic wood, or fluff)

The key component of the eddy current separator is the magnetic rotor, which has a series of permanent rare earth magnets mounted on a support plate attached to a shaft. The magnetic rotor is surrounded by a wear shell which supports the conveyor belt. This allows the rotor to spin independently and at a much higher speed than the wear shell and belt around it.

When a piece of non-ferrous metal (such as aluminum) passes over the separator, the magnets inside the rotor rotate past the aluminum at high speed. This forms eddy currents in the aluminum which, in turn, creates a magnetic field around the piece of aluminum. The polarity of that magnetic field is the same as the rotating magnet, causing the aluminum to be repelled away from the magnet. This repulsion makes the trajectory of the aluminum greater than that of the nonmetallic metal, allowing the two material streams to be separated.

Eddy Current Eccentric Design Operation

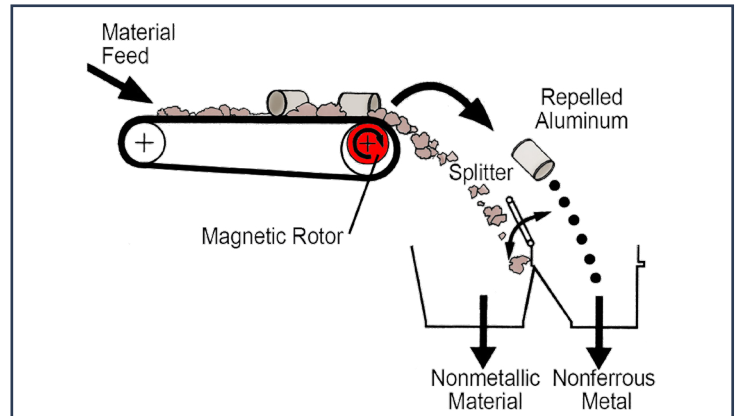

Separates non-ferrous from fractional sizes up to the size of aluminum cans from a paper and plastic product stream in a low to medium level throughput.

The off center "eccentric" magnet design of the rotor allows ferrous metal that made it past the upstream magnetic separator to be released from the belt as it leaves the magnetic area of the outer rotor shell. This reduces the likelihood that ferrous metal will cling to and damage the belt and shell, extending rotor life.

Rotor Features & Design

Eccentric Rotor Features & Specifications

- ◇ Adjustable rotor speed
- ◇ Rotor construction optimized for:
 - High speed operation - up to 3000 RPM
 - Quiet operation / low vibration
- ◇ Stainless-steel rotor heads
- ◇ Oversized, high-speed, self-aligning rotor bearings
- ◇ High-temp filament wound outer shell
- ◇ Epoxy encapsulated magnets eliminates rotor imbalance due to magnet movement
- ◇ Stainless rotor shell
- ◇ Easily adjust rotor position to optimize separation efficiency

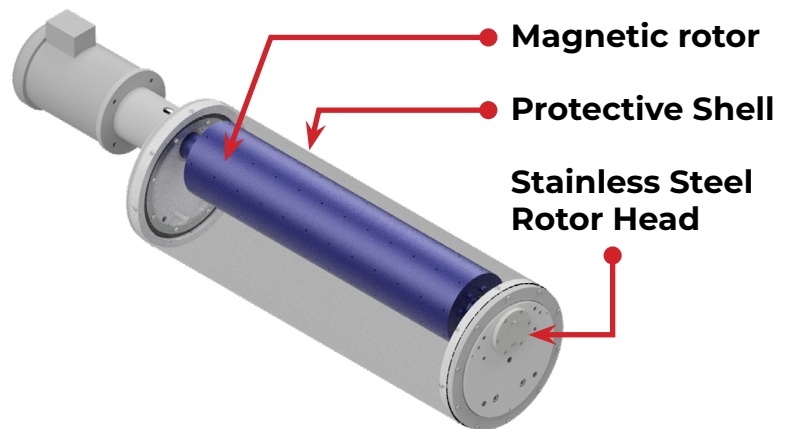

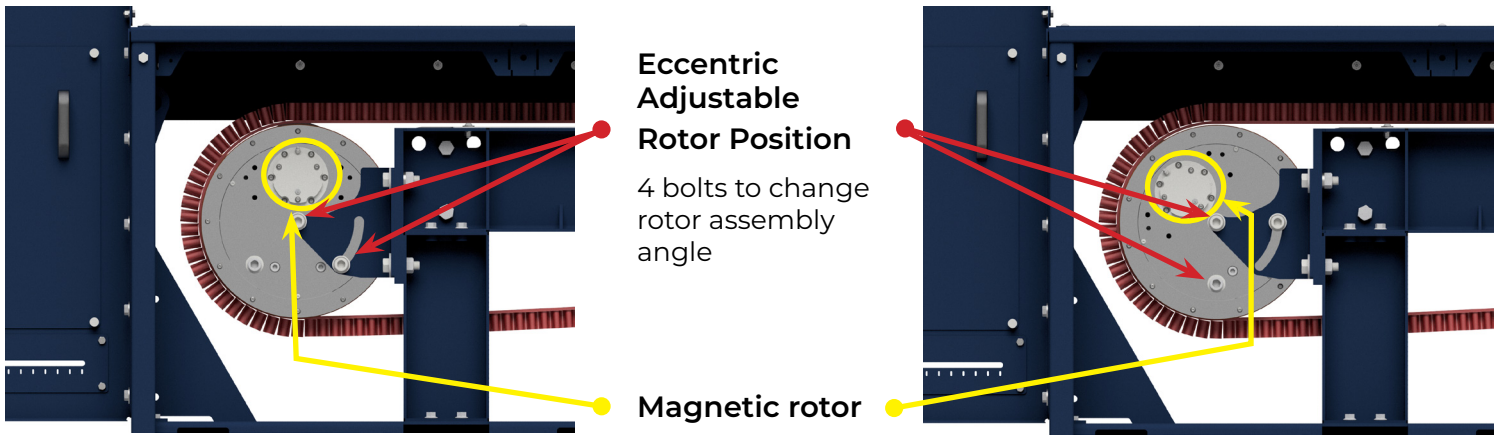

Eccentric Adjustable Rotor Position
4 bolts to change rotor assembly angle

Magnetic rotor

Eddy Current Eccentric Design Magnetic Field

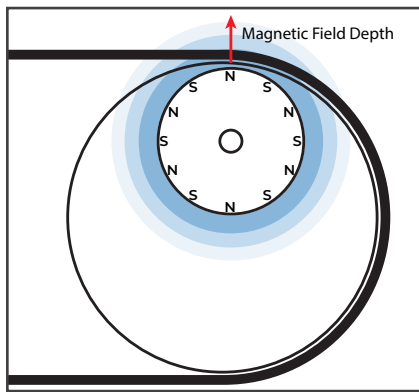

High frequency magnetic pole change & high magnetic strength provide superior product separation.

Note:
The 9900 Model's magnetic field is the same as the 9100 version. However, its off-center rotor design allows ferrous metal to be released rather than cling to the magnetic pulley.

Eddy Current Eccentric Design Dual-Layer Shell

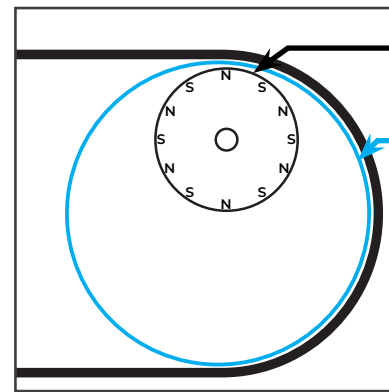

Heavy-Duty Stainless Steel Cover

Fiberglass Wear Shield

This dual layer design provides maximum rotor protection that gives the equipment longer life, lower maintenance and repair costs and simplifies maintenance of the equipment.

Belt Features & Design

Eccentric Belt Features & Specifications

- ◇ Easy to replace - less than 15 minutes
- ◇ High quality, endless polyurethane belt
- ◇ Corrugated sidewalls for long life and material containment
- ◇ Adjustable belt speed
- ◇ Belt sizes 36", 48" and 60" widths

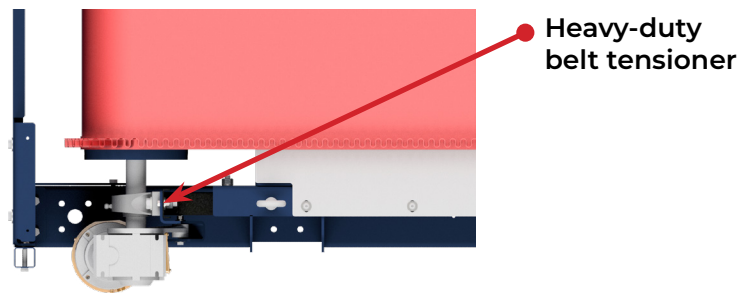

Heavy-duty belt tensioner

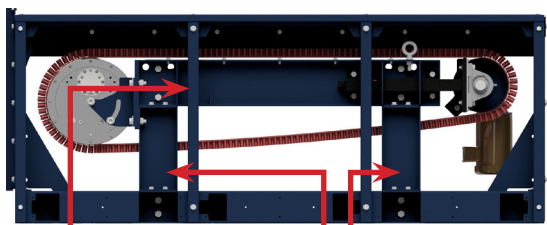

Cantilevered Frame
makes endless belt replacement simple, 15 minutes or less.

Easy-to-remove supports

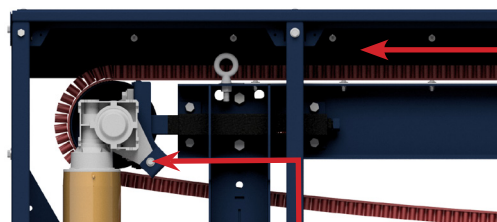

Belt motor mounted take-up
moves with take-up for easier belt adjustment

Corrugated side walls
for material containment

General Construction

Eccentric Separator General Construction

- ◇ Easy to remove access panels - reduces maintenance time & cost
- ◇ Door design is self-aligning and self-supporting

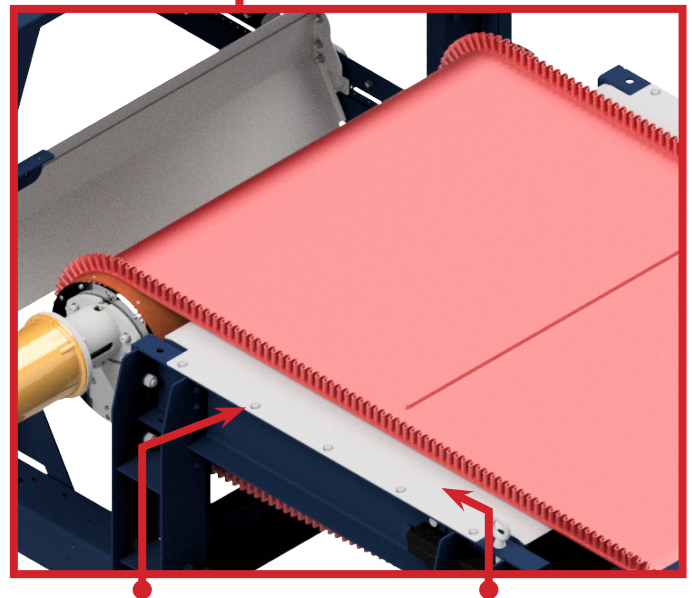
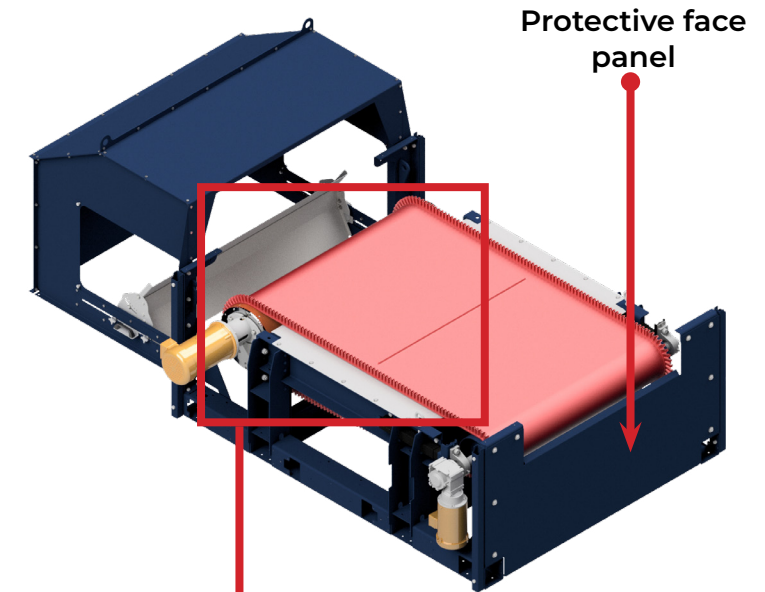
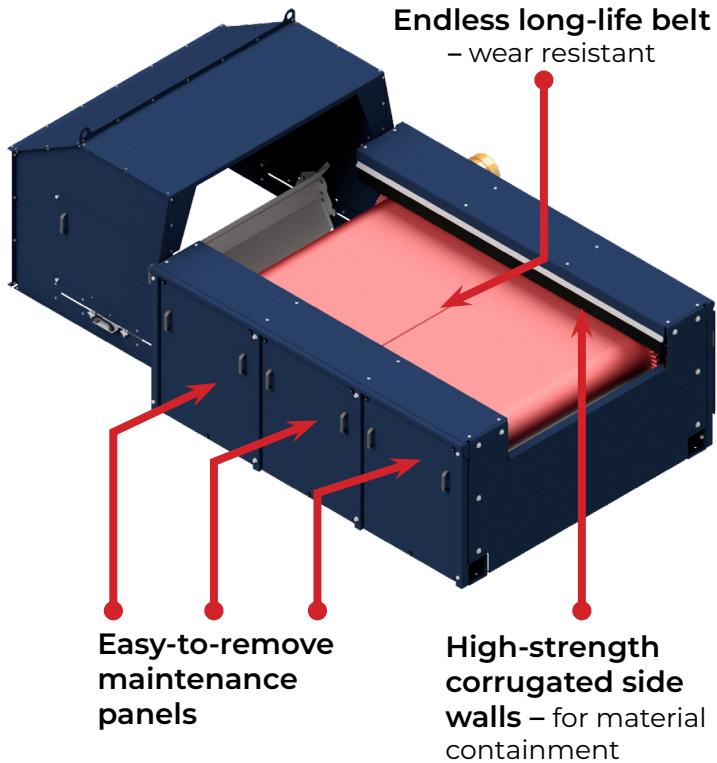

Mounting screws
outside belt running path

Fully supported bed

Motor Features & Specifications

Eccentric Separator Motor

- ◇ Magnetic rotor motor & conveyor belt motor
- ◇ Belt motor moves with the take-up for easier belt adjustment
- ◇ Telescoping take-up frames designed to prevent freeze-ups – Easy-to-adjust & sealed
- ◇ Curve-crowned belt drive pulley – better belt tracking
- ◇ Class II gear motor with synthetic oil for high & low ambient temperatures

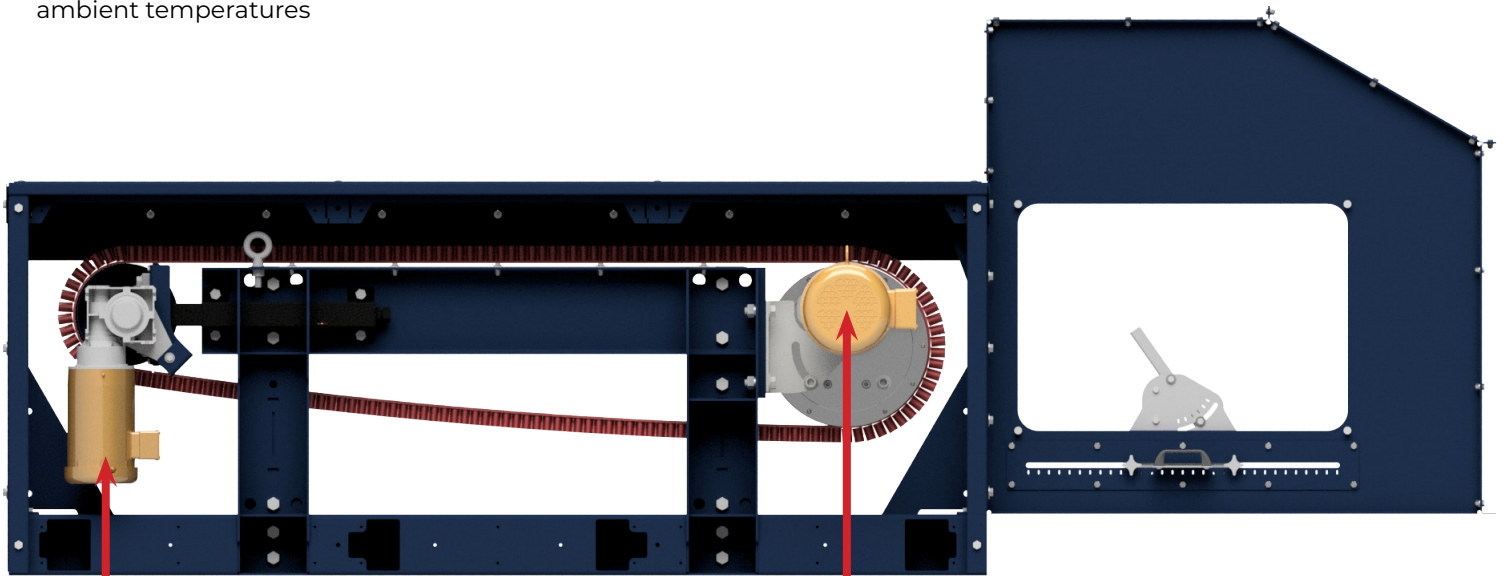

Direct drive motors
no belts means fewer
wear parts

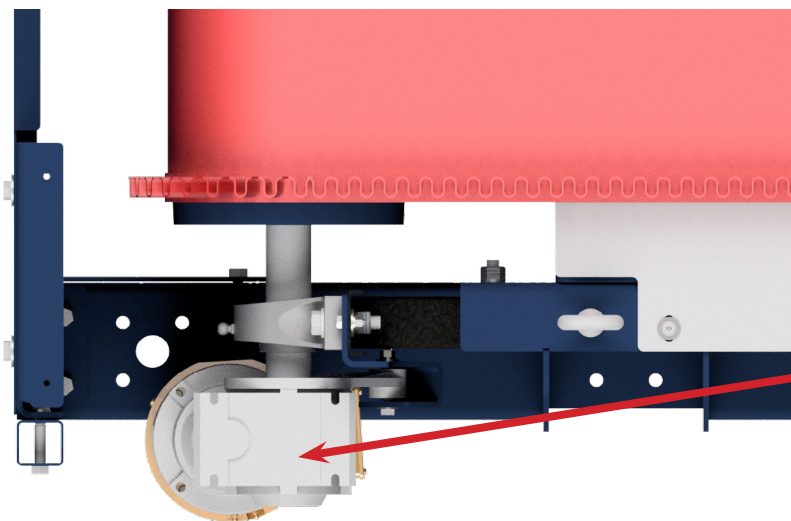

**No torque arm
adjustment needed**
gear motor moves with
the take-up

Splitter/Hopper & Other Eddy Current Options

Eccentric Separator Optional Splitter/Hopper

- ◇ Bolt together design - detachable for easy shipment & assembly in field
- ◇ Large, easy-to-remove sight panels for accurate adjustments of splitter
- ◇ Three degrees of adjustability for optimized separation Angle, height & distance
- ◇ Lifting lugs designed at center of gravity point
- ◇ Lifting lugs designed at center of gravity point
- ◇ Stainless-steel splitter construction

Other Eddy Current Options

- ◇ Standard & Non-Standard Variable Speed Belt & Rotor Control Panels
- ◇ Fixed Speed Control Panel; UL/CSA Control Panels
- ◇ Belt Tracking Sensor
- ◇ Custom Lengths & Heights

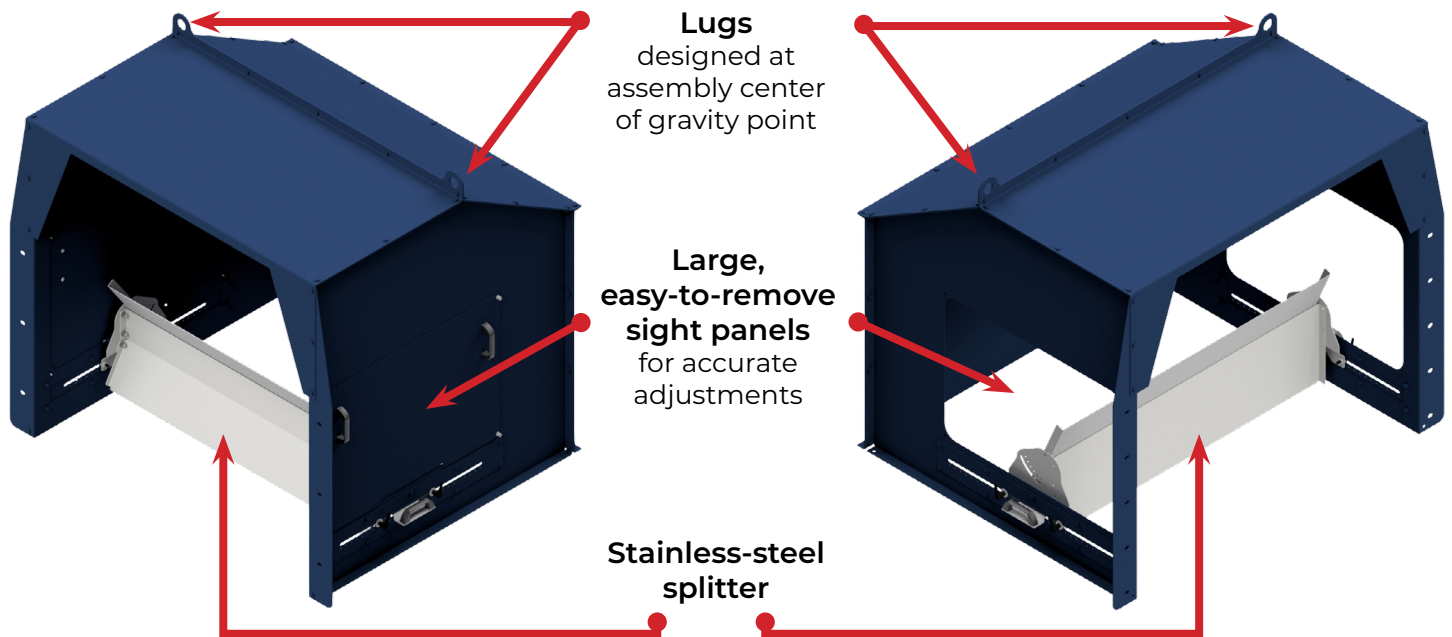

Splitter Adjustments

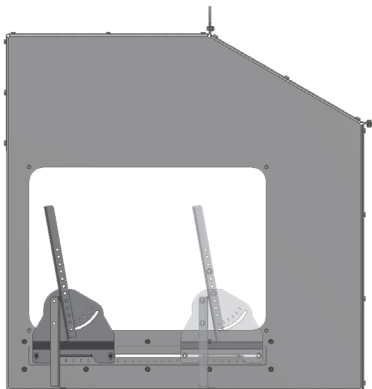

1. Distance Adjustment

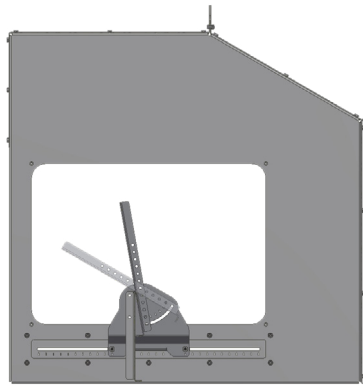

2. Angle Adjustment

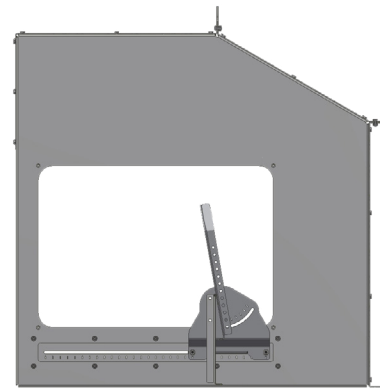

3. Height Adjustment

Other Models & Dings Equipment

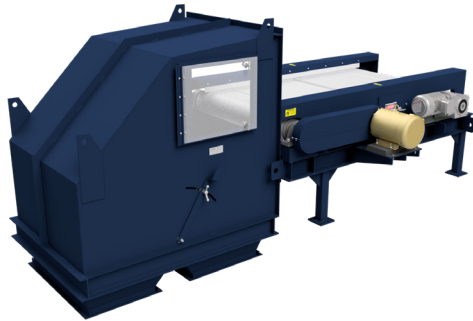

Model 9100
Magnetic Pulley Diameter: 7"
Belt Width: up to 48"

Applications: Ideal for separating non-ferrous from fractional sizes up to the size of aluminum cans from a paper and plastic product stream in a low to medium level throughput.

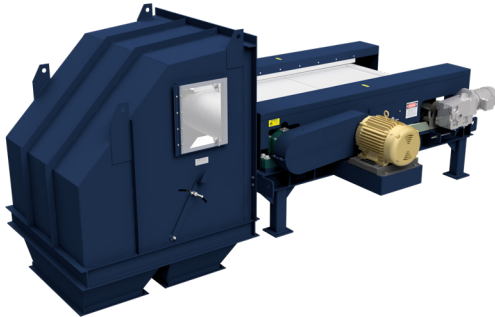

Model 9500
Magnetic Pulley Diameter: 13"
Belt Width: Up to 72"

Applications: Ideal for separating aluminum cans and other non-fractional sized non-ferrous metal from a paper and plastic product streams. The 9500's larger magnetic rotor size allows for a heavier throughput over the smaller 9100 or eccentric models.

More Dings Company Magnetic Separation Equipment

Severe Duty Overhead Self-Cleaning Electromagnet

"Durabelt" Stainless steel pads and cleats

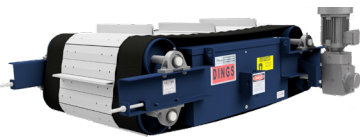

Overhead Self-Cleaning Electromagnet

20-year warranty on coil burnout



Deep Drum Magnet



Magnetic Head Pulley

Available in 3 different strength series



MRF (Material Recovery Facility) Overhead Self-Cleaning Electromagnet

3" high cleats



Engineering Driven - Customer Service Focused



Powerful Magnetic Products Since 1899

Dings Company Magnetic Group engineering and sales staff work together from our Milwaukee, WI factory to provide outstanding customer service from experts in magnetic separation. First, we listen to our customers to gain an understanding of their needs. Then we apply our experience in their trade to provide magnetic separation equipment that is sized and positioned for the best possible performance in their specific application.