

Magnetic Drum:

Type PC & Type FC

- ◇ Rugged, dust-tight construction with stainless steel shell
- ◇ Continuous, low-cost separation
- ◇ Easily integrated into existing production processing systems
- ◇ Self-aligning bearings
- ◇ Designed with Ceramic VIII magnetic material

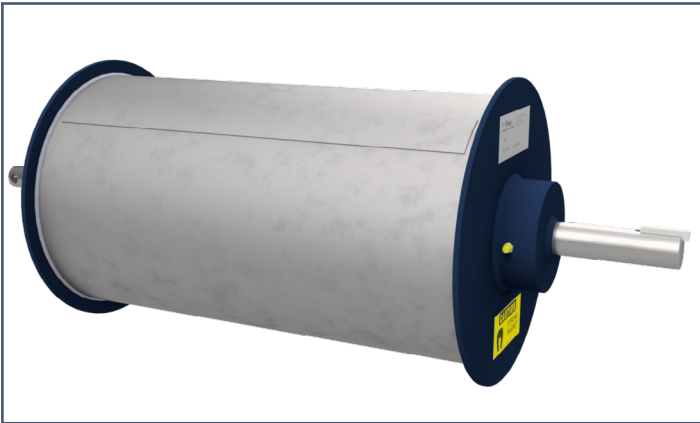

Dings Type PC Drum mounts easily with a pillow block bearing and shaft clamp and can be fed manually or integrated into an existing production system. The PC Drum comes with a choice of standard (radial) or agitating (lateral) pole designs.

Dings Magnetic Drums are designed to continuously remove large quantities of ferrous metals for product purification in free-flowing powders and granular materials or to concentrate and reclaim product in recycling. Magnetic Drums also protect processing equipment and prevent costly repairs and downtime caused by tramp iron damage. Their self-cleaning design means no interruptions in product flow for cleaning cycles. High-strength, lifetime guaranteed permanent magnets function at top efficiency, day in and day out. Dings drum magnets feature our DFC magnetic circuit. This unique design ensures a uniform magnetic field across the entire surface of the magnet.

Dings Flux Control (DFC) Circuit

Dings Flux Control (DFC) Circuit design eliminates internal leakage between magnetic poles and improves separating performance. Other 'conventional' magnetic circuits contain air or filler material between the magnetic poles; this allows flux (magnetism) to escape (leak out) and be wasted. In Dings DFC design - blocking magnets are strategically positioned in the spaces between the magnetic poles. These redirect the flux outward, into your product, converting the wasted flux into working force - making the magnet more efficient.



Dings Type FC Drum is a PC Drum furnished with a totally enclosed drive motor, feed leveler, splitter and flanged housing.

Dings DFC Design improves the overall performance of the magnet in 3 ways

- ◇ The magnetic field is stronger
- ◇ The magnetic field extends deeper
- ◇ The magnetic field pattern is more uniform



On Magnetism
for all Permanent
Magnets

Conventional Magnetic Circuit
With "filler" between the poles

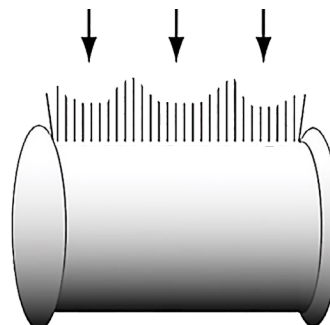

leakage

Dings Magnetic Circuit
with blocking magnets
between the poles

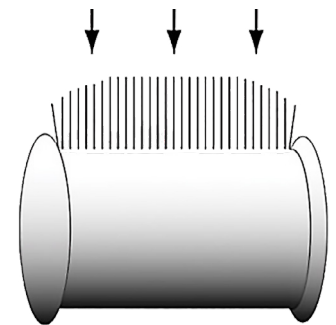

No leakage

Feed Arrangements

Dings Deep Draw Drum can be fed in any position. After mounting, the magnet arc is adjusted to match the feed location. Feed position can affect the purity of recovered ferrous metal.

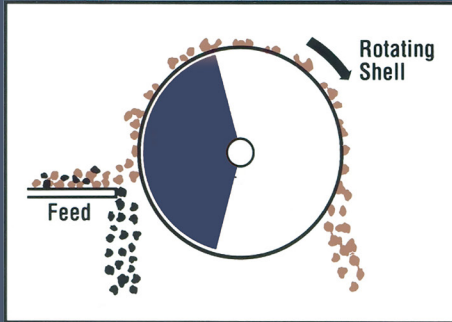

Up-and-Over Feed

Ferrous is lifted out of the burden and carried up and over the magnet while the nonferrous material drops off the feeder.

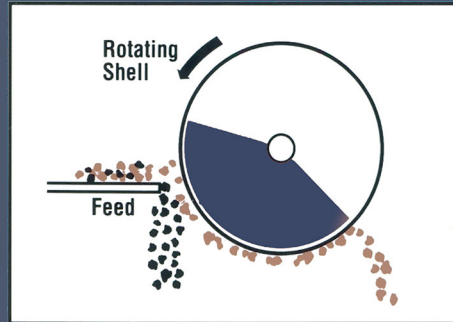

Down-and-Under Feed

This arrangement has the shortest and most direct transfer area for the ferrous.

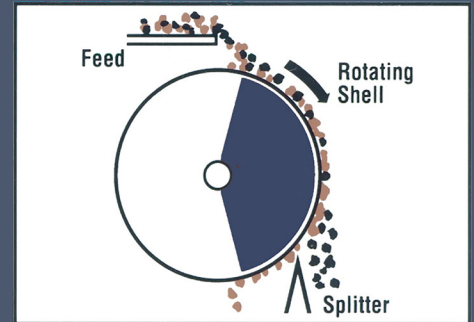

Top Feed

The top feed arrangement is used with weakly magnetic ferrous or nonferrous pieces too large to pass through a reasonable gap setting.

***FC Drum Model: Top Feed Only**

More Dings Company Magnetic Separation Equipment

Ferroplate Magnet

Lifetime warranty on magnetism



Magnetic Head Pulley

Available in 3 different strength series



Heavy-Duty Pit Magnet

Lifetime warranty on magnetism



Overhead Self-Cleaning Electromagnet

20 year warranty on coil burnout



Eddy Current Separator

Separate non-ferrous metal

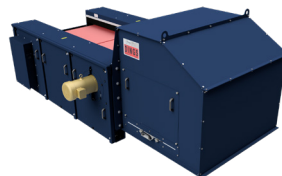

Overhead Self-Cleaning Permanent Magnet

Lifetime warranty on magnetism

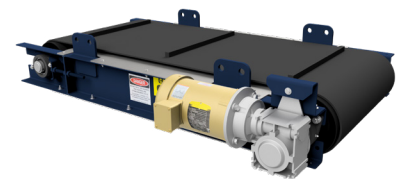

ver.10/24

Engineering Driven - Customer Service Focused



Dings Company Magnetic Group engineering and sales staff work together from our Milwaukee, WI factory to provide outstanding customer service from experts in magnetic separation. We listen to our customers to gain an understanding of their needs and apply our experience in their trade to provide magnetic separation equipment that is sized and positioned for the best possible performance in their specific application.

Magnetic Drum Quote Request

Company: _____ Quote Required Date: _____

Address: _____ Contact Person: _____

City, State, ZIP: _____ Contact Email: _____

Phone/Cell: _____ Email Completed RFQ to: magsales@dingsco.com

Date Equipment Required by: _____ ***You Must Select One to Print: Imperial Metric**

Application Information

Type of Material Being Conveyed: _____

Size of Material Being Conveyed: _____

Description of Largest Ferrous Pieces Being Removed: _____

Description of Smallest Ferrous Pieces Being Removed: _____

Feeder Belt Width: _____ Burden Depth: _____

Feeder Belt Speed: _____ Ferrous to Burden: _____ % percent

Feed Rate: _____

Supply Requirements: Volts: _____ Phase: _____ Cycles Per Second (Hz): _____

Special Requirements: _____

Magnetic Drum Selection

Feed Arrangement:

Drum Diameter Size:

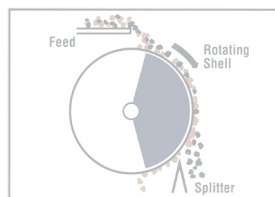
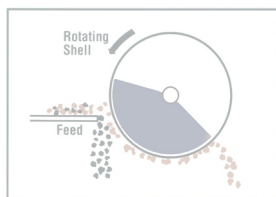
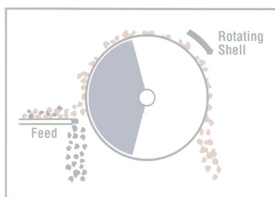

***FC Drum Model:**
Top Feed Only

Model Type: Drum Only (type PC):

Drum with Housing (type FC):

Special Requests: _____

Configuration:

Single:

Double:

Triple:

ver. 10/24