



Engineering Driven
Customer Service Focused

Providing Engineered
Magnetic Solutions for **125** Years

www.dingsmagnets.com | magsales@dingsco.com
(414)672-7830

Magnetic Separation for Recycling Applications



Call us for Expert Support of Dings Co. Equipment - Regardless of its Age

Overhead Self-Cleaning Magnetic Separators

- ◇ Automatic continuous separation saves time and labor costs.
- ◇ Stainless steel bottom and center wear plate provides extra protection in the main impact area
- ◇ Multi-ply rubber belt with hot vulcanized 1" cleats for superior adhesion

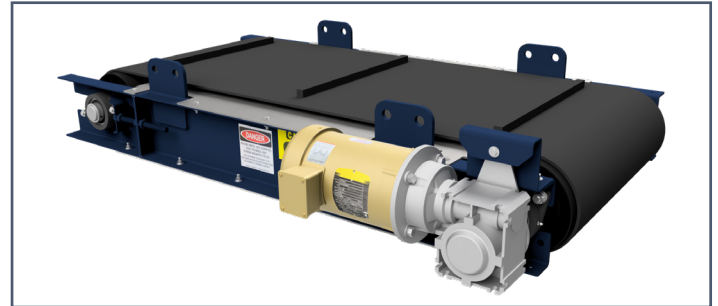

Dings Self-Cleaning Electromagnet

Dings Self-Cleaning Models' belt continuously travels across the face of the magnet to automatically discharge tramp iron. It comes equipped with a multi-ply rubber belt with 1 inch hot vulcanized cleats.

- ◇ Balanced Magnetic Circuit for maximum efficiency and equal distribution of length, width and depth of magnetic circuit
- ◇ Terminal connection box is NEMA 4 weather tight
- ◇ Stainless steel bottom and center wear plate provides extra protection in the main impact area

Dings Self-Cleaning Permanent Magnet

The belt continuously travels across the face of the magnet to automatically discharge tramp iron. It comes equipped with a multi-ply rubber belt with 1 inch vulcanized cleats.

- ◇ Unique construction - the best ratio of field strength produced per size & weight of any in the industry!
- ◇ Magnet housing filled with Ceramic VIII magnet material.
- ◇ Non-magnetic stainless steel construction that prevents collection of ferrous metals on the magnet frame.

Dings Electromagnetic Coils

- ◇ No insulation is needed with anodized aluminum straps—eliminating the major cause of coil failure (insulation breakdown)
- ◇ More magnetism and separating power - generated by extra turns
- ◇ Each turn is exposed to cooling oil - assuring a stronger, more efficient magnet
- ◇ Eliminates the need for external oil expansion pipes or tanks that require maintenance and can be damaged

Dings DFC Design improves the overall performance of the magnet in 3 ways

- ◇ The magnetic field is stronger
- ◇ The magnetic field extends deeper
- ◇ The magnetic field pattern is more uniform



On Magnetism for all Permanent Magnets

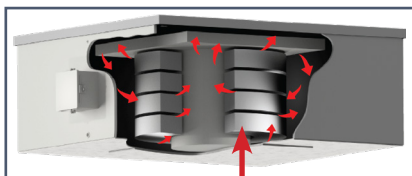

Oil Flow =  Anodized Aluminum Strap



20-Year Warranty on Coil Burnout "Best in Industry"

Conventional Magnetic Circuit With "filler" between the poles

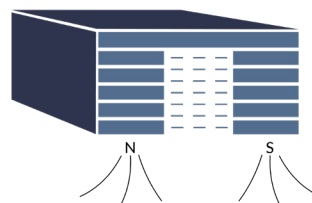

--- Indicates flux leakage in airspace

Dings Magnetic Circuit with blocking magnets between the poles

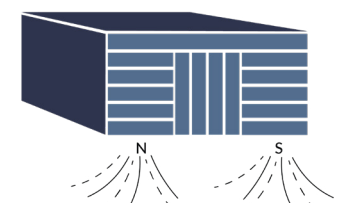

--- Indicates leakage converted to work force

Eddy Current Separator: Concentric & Eccentric Designs

- ◇ Recover valuable non-ferrous
- ◇ Layered Shell designs protects valuable components
- ◇ Polyurethane or nitrile wear resistant belt.
- ◇ Belt motor moves with take-up assembly for easy tracking and adjustment
- ◇ Oversized, high speed rotor bearings & shaft

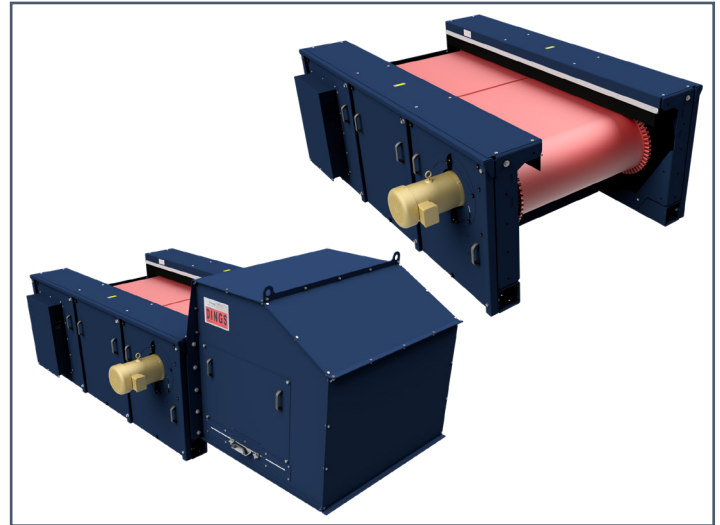
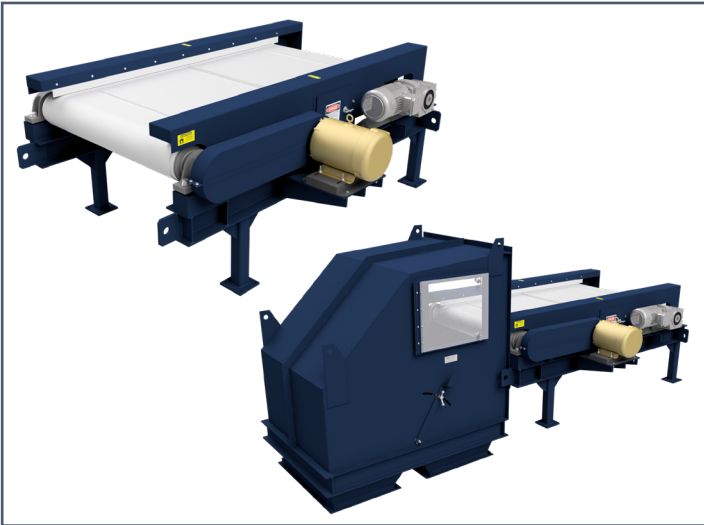

Dings Eddy Current Concentric Design

9100: Ideal for separating non-ferrous from fractional sizes up to the size of aluminum cans from a paper and plastic product stream in a low to medium level throughput.

9500: Ideal for separating aluminum cans and other non-fractional sized non-ferrous metal from a paper and plastic product streams. The 9500's larger magnetic rotor size allows for a heavier throughput over the smaller 9100 or eccentric models.

Dings Eddy Current Eccentric Design

Ideal for separating non-ferrous from fractional sizes up to the size of aluminum cans from paper and plastic product streams in a low to medium level throughput. The 9900 has added features like access panels for easily replaceable belts and maintenance.

Eddy Current Concentric Design

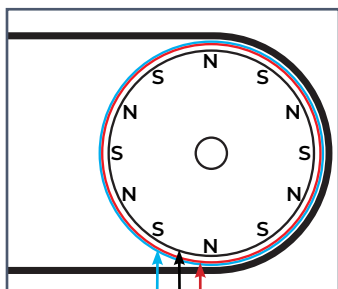

Ceramic Tile Shell Cover
Fiberglass Rotor Shell
Heavy-Duty Stainless Steel Rotor Cover

Eddy Current Eccentric Design

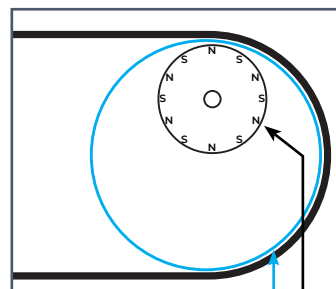

Fiberglass Wear Shield
Heavy-Duty Stainless Steel Cover

Eddy Current Concentric Design Magnetic Field

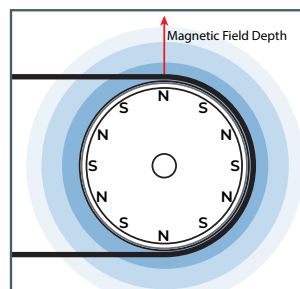

Note: Depth of magnetic field is relative to the size of magnets inside the rotor. For example the 9500 Model has a larger/deeper field in comparison to the 9100.

Eddy Current Eccentric Design Magnetic Field

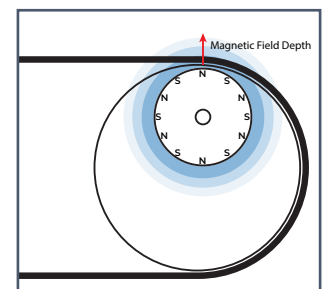

Note: The 9900 Model's magnetic field is the same as the 9100 version. However, it's off-center rotor design allows ferrous metal to be released rather than cling to the magnetic pulley.

Deep Draw Drum:

- ◇ Designed with Ceramic VIII magnetic material encapsulated in stainless steel.
- ◇ Drum can be fed at any position with an adjustable internal magnet assembly
- ◇ Replaceable heavy duty manganese cover extends drum life
- ◇ Lateral or radial pole designs
- ◇ Magnetic adjusting arm rotates the magnet clockwise or counterclockwise
- ◇ Drum sized more efficiently for significant cost savings

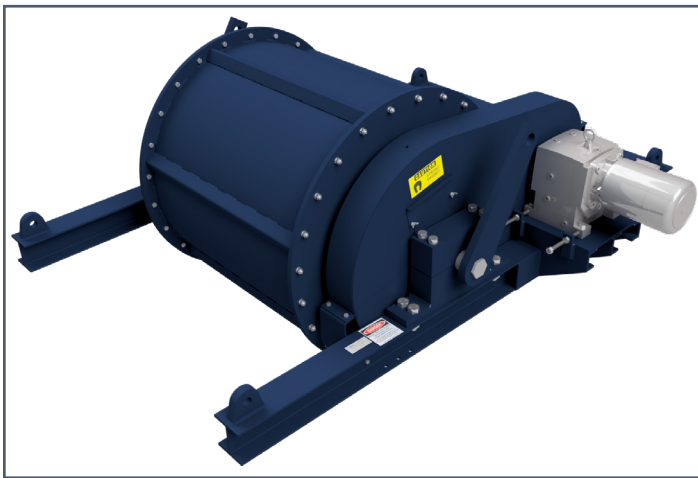

Dings Deep Draw Drums are specially designed for heavy duty, high-volume ferrous recovery. This large and powerful magnetic drum has a nonmagnetic outer shell that is driven around a fixed magnet. Ferrous metal is magnetically drawn out of the material feed, held against the rotating shell, and then released at the discharge point. Our Deep Draw Drum has the rugged construction needed for separating ferrous metal from the material stream in shredded cars, scrap metals, municipal solid waste, wood waste, slag, recycling crushed ore, ash at mass burn-out plants, and more. The Deep Draw Drum can be fed at multiple positions since the internal magnet assembly is adjustable.

The Dings Deep Draw Drum's permanent magnet design outperforms electric-powered models in a number of important ways, it always operates at top efficiency and maintains a constant magnetic strength throughout the day.

Dings Flux Control (DFC) Circuit

Dings Flux Control (DFC) Circuit design eliminates internal leakage between magnetic poles and improves separating performance. Other 'conventional' magnetic circuits contain air or filler material between the magnetic poles; this allows flux (magnetism) to escape (leak out) and be wasted. In Dings DFC design - blocking magnets are strategically positioned in the spaces between the magnetic poles. These redirect the flux outward, into your product, converting the wasted flux into working force - making the magnet more efficient.

Dings DFC Design improves the overall performance of the magnet in 3 ways

- ◇ The magnetic field is stronger
- ◇ The magnetic field extends deeper
- ◇ The magnetic field pattern is more uniform



On Magnetism
for all Permanent
Magnets

Conventional Magnetic Circuit
With "filler" between the poles

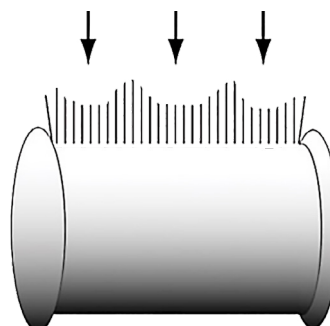

leakage

Dings Magnetic Circuit
with blocking magnets
between the poles

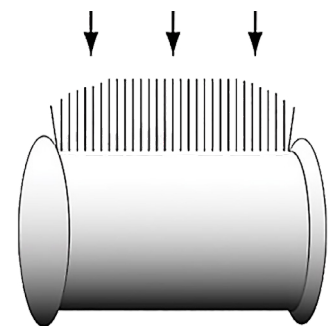

No leakage

Magnetic Head Pulleys

No Cost Operation

- ◇ Dings Flux Control (DFC) Circuit on our DFC Ultra Model
- ◇ Automatic and continuous separation
- ◇ Easily integrated into existing processing systems
- ◇ Magnet assembly filled with Ceramic VIII magnet material
- ◇ Type 304 nonmagnetic stainless steel shell

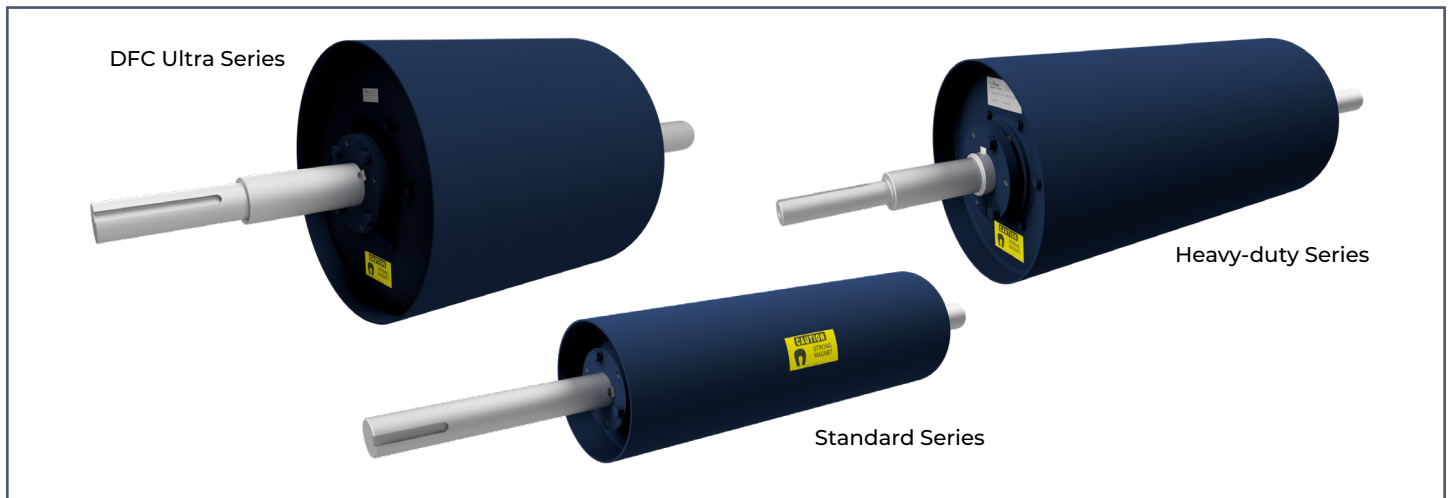

Magnetic Head Pulleys

Are non-electric, self-cleaning magnetic separators. They operate as head pulleys on conveyors to separate tramp iron and iron impurities from materials conveyed in bulk form. They are designed for machinery protection and product purification. Our magnetic head pulley's magnetism is produced by an internal ceramic magnet assembly that is enclosed with a nonmagnetic stainless steel shell.

Magnetic Head Pulley Operation & Strength

Since every application has its own specific needs regarding the magnetic depth of field required, Dings Company Magnetic Group is the only company to offer you three different magnetic strengths.

Magnetic Head Pulley Material Trajectory

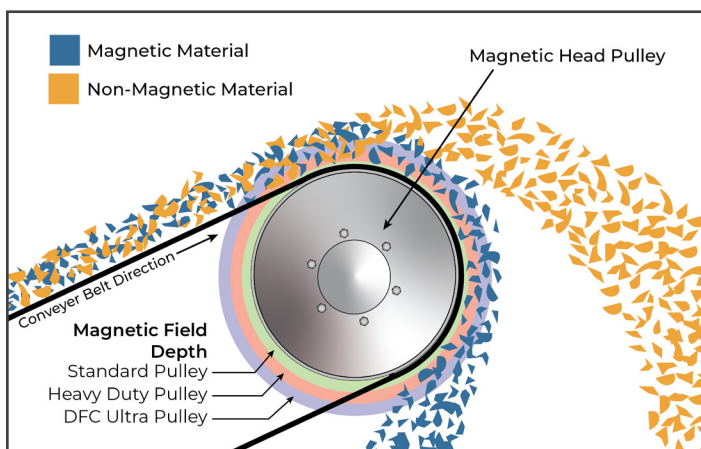

Dings Standard

8", 12" 15" 18" 20" & 24"
Diameters

Dings Heavy Duty

12", 15", 18", 20", 24", 30", 36" & 42"
Diameters

Dings DFC Ultra

12", 15", 18", 20", 24", 30", 36" & 42"
Diameters

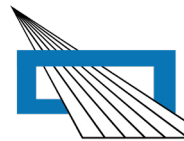
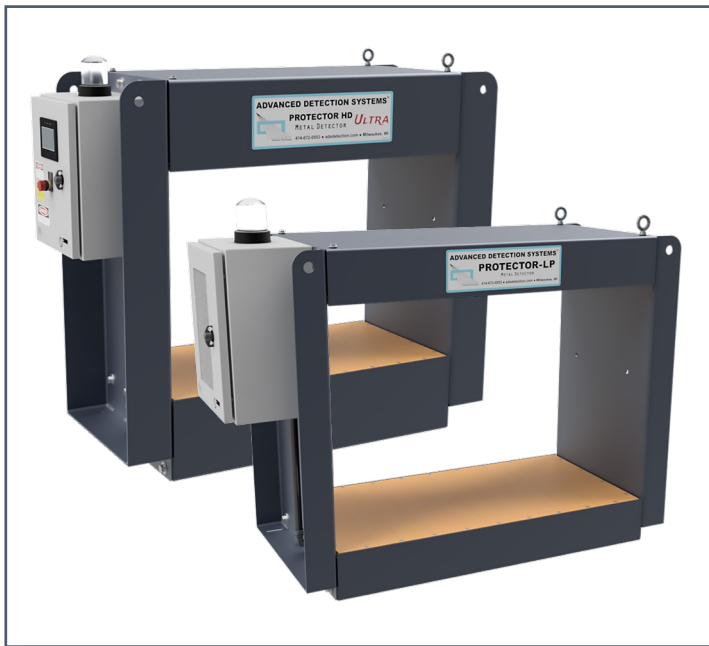

**ADVANCED
DETECTION
SYSTEMS®**
Metal Detection Experts

A Sister Company of
Dings co. Magnetic
Group

Protect Your Corrugated Recycling Process from Dangerous Metallic Contaminants

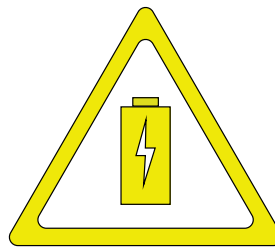

SurroundScan Protector Series Metal Detectors from ADS

Catch lithium-ion batteries
and other dangerous metallic
contaminants in your recycling
process before they can cause
fires..

Engineering Driven - Customer Service Focused



Providing Engineered
Magnetic Solutions for **125 Years**

Dings Company Magnetic Group engineering and sales staff work together from our Milwaukee, WI factory to provide outstanding customer service from experts in magnetic separation. We listen to our customers to gain an understanding of their needs and apply our experience in their trade to provide magnetic separation equipment that is sized and positioned for the best possible performance in their specific application.