

## Grate Magnets:

- ◇ Guaranteed Lifetime Warranty on magnetism
- ◇ Designed with Ceramic VIII magnetic material or Rare Earth Magnets available
- ◇ Heavy duty, all-welded models
- ◇ Continuous and/or automatic separation
- ◇ Maintenance-free and easy-to-use models
- ◇ Dust-tight construction

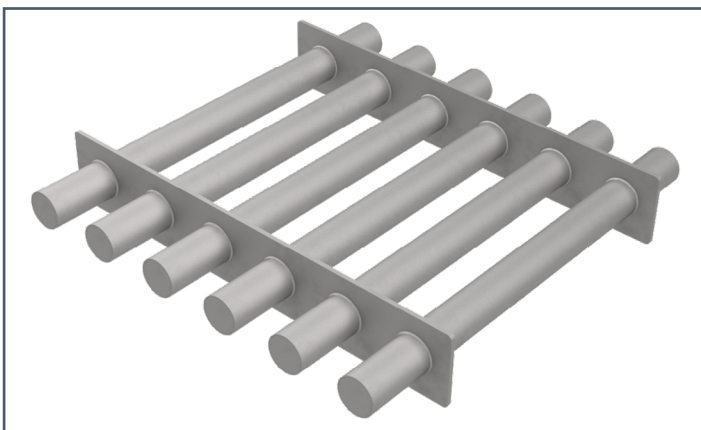

Grid Magnet

**Dings Grate Magnets** are powerful, non-electric separators designed to remove small magnetic particles from free-flowing powders and granular materials. Dings Grate magnets are made with permanent magnets, therefore the magnetism is guaranteed for life. Magnetism is spread across the entire space where material flows. It's concentrated on the smooth surfaces of magnetic tubes, and in the spaces near them. All material fed into a Grate Magnet is subjected to a magnetic separating force. Dings Grate Magnets contain magnetic material throughout the entire tube to produce a more uniform separating force, unlike other grate magnets that are partially loaded with springs and fillers.

Grate Magnets are built in a variety of designs from drawer types to floor types. They fit vertical flow chute applications more easily, more effectively and more economically than other separator types. They cost nothing to operate!



Heavy-Duty Pit Magnet (shown with deflectors)

## Dings Grate Magnet Models

**Dings Grate Magnets** are available in a variety of designs and models: Rotary, Hopper, Easy Clean, Auto Clean, Heavy Duty Pit, Standard Housed, Drawer, Heavy Duty Frame and much more. Contact a Dings magnetic expert today to get the right Grate Magnet for your application.

Options: Sanitary finish, deflectors, double bank, drum adapters, hopper adapters, bin vibrators (pneumatic and electromagnetic), transitions, collections trays, rare earth magnetic material, custom designs.

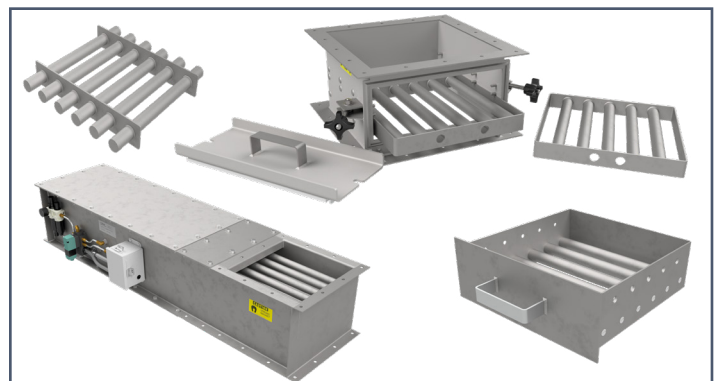

# Superior Grade Ceramic VIII

Dings Co. uses the best grade of ceramics for magnet tubes, ensuring a stronger, longer lasting magnetic field. Ceramic VIII has a better resistance to demagnetization than Ceramic V or other lower grade materials.

This resistance is particularly important in grates because of the arrangement of polarities inside the tubes. For maximum separating power, the magnetic components must be assembled in the tubes with like poles facing each other. However, these repelling poles create a strong demagnetizing force which can weaken the performance of the grate magnet. Ceramic VIII was developed specifically to overcome this negative effect, making it the ideal material for grate magnets.



**On Magnetism  
for all Permanent  
Magnets**

## More Dings Company Magnetic Separation Equipment

### Ferroplate Magnet

Lifetime warranty on magnetism



### Pneumatic Inline Magnet

Powerful rare earth magnets available



### Quick Clean Perma Chute Magnet

Lifetime warranty on magnetism

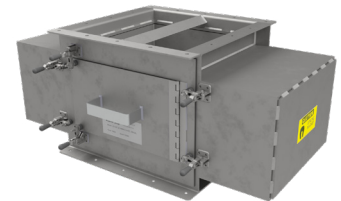

### Rare Earth Ferroplate Magnet

More holding power



### Magnetic Head Pulley

Available in 3 different strength series



### Eddy Current Separator

Separate non-ferrous metal

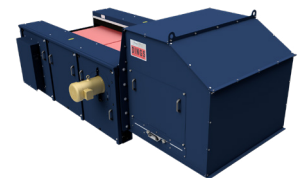

### Overhead Self-Cleaning Electromagnet

20 year warranty on coil burnout



### Deep Draw Drum

Lifetime warranty on magnetism



### Overhead Self-Cleaning Permanent Magnet

Lifetime warranty on magnetism

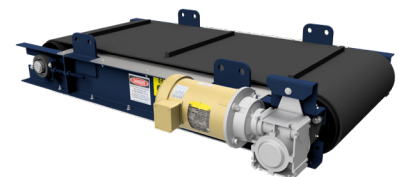

## Engineering Driven - Customer Service Focused

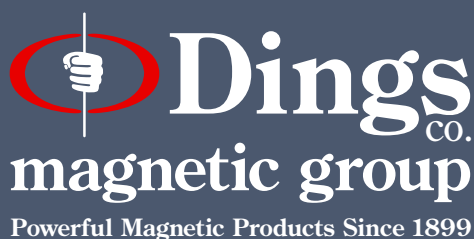

Dings Company Magnetic Group engineering and sales staff work together from our Milwaukee, WI factory to provide outstanding customer service from experts in magnetic separation. We listen to our customers to gain an understanding of their needs and apply our experience in their trade to provide magnetic separation equipment that is sized and positioned for the best possible performance in their specific application.