

## Eddy Current Separator: Concentric 9100 Model

Engineered for Separating  
Fractional Sized Non-Ferrous  
Up to Aluminum Cans

- ◇ Economical solution for recovering non-ferrous from fractional sizes to aluminum cans
- ◇ Triple layer shell design protects valuable components
- ◇ Stainless-steel interior rotor shell around high strength rare earth magnets
- ◇ Polyurethane or nitrile wear resistant belt.
- ◇ Belt motor moves with take-up assembly for easy tracking and adjustment
- ◇ Oversized, high speed rotor bearings & shaft

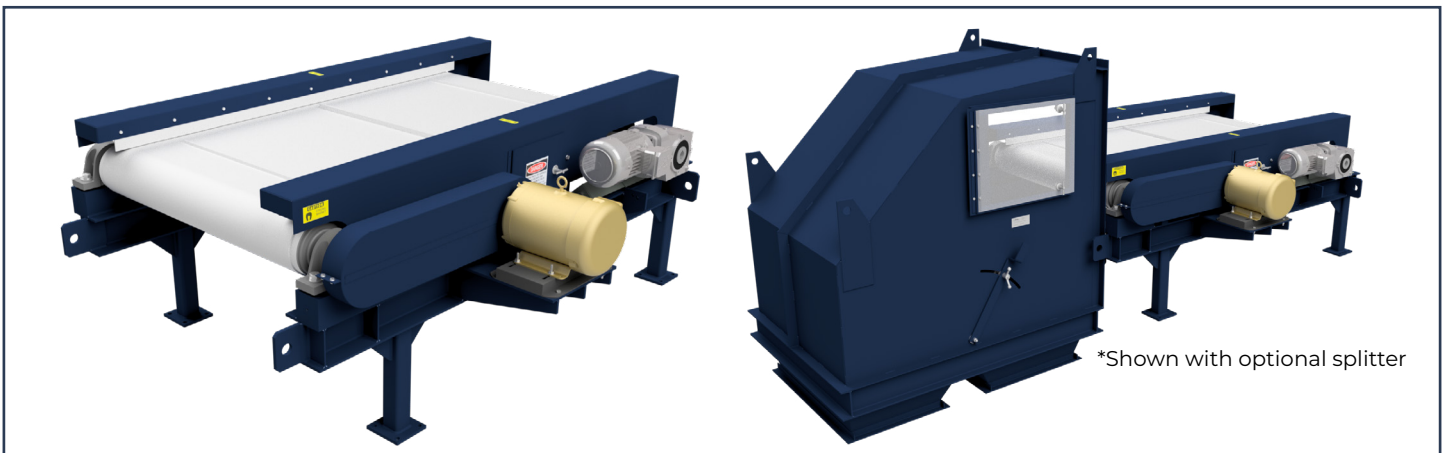

### Eddy Current Separators

An Eddy Current Separator is designed to recover nonferrous metal from non-metallic material such as commingled recyclables, plastics, glass, material processed at composting or waste-to-energy facilities, auto shredder residue, and various other industries. Our Eddy Current Separators provide significant savings on labor costs by reducing the man hours required for manual sorting. They are engineered for dirty, dusty and severe outdoor surroundings found at many job sites. The permanent rare earth magnets used in our Eddy Current Separators provide larger and deeper magnetic fields that are well-suited for industrial applications. These expanded magnetic fields also tolerate deeper burdens than the competition. Dings' renowned customer service and support is what separates us from the rest.

### Eddy Current Separation Operation

When a piece of non-ferrous metal such as aluminum, passes over the separator, the magnets inside the rotor rotate past the aluminum at high speed. This forms eddy currents in the aluminum, creating a magnetic field inside the piece of aluminum. The polarity of that magnetic field is the same as the rotating magnet, causing the aluminum to be repelled away from the magnet. This repulsion makes the trajectory of the aluminum greater

than that of the nonmetallic material, allowing the two material streams to be separated.

### Dings Eddy Current 9100 Concentric Model

Ideal for separating non-ferrous from fractional sizes up to the size of aluminum cans from a paper and plastic product stream. The 9100's concentric design has a triple layered shell consisting of an outer layer of ceramic tile and fiberglass around a heavy duty stainless steel inner shell to protect the magnetic rotor assembly. This design lowers maintenance and replacement costs.

- ◇ Generate income by recovering non-ferrous metals.
- ◇ Rare earth magnets provide high strength & long life.
- ◇ Deep magnetic field increases non-ferrous recovery.
- ◇ Heavy duty structural steel I-beam frame and support structure.
- ◇ Oversized shafts and bearings, and a heavy duty drive package
- ◇ Optional integrated adjustable splitter with clear inspection doors provide access to the splitter.
- ◇ Save on costs of manual sorting.
- ◇ Fits easily into your existing line.

## Eddy Current 9100 Concentric Model Operation

Ideal for separating non-ferrous from fractional sizes up to the size of aluminum cans from a paper and plastic product stream in a low to medium level throughput.

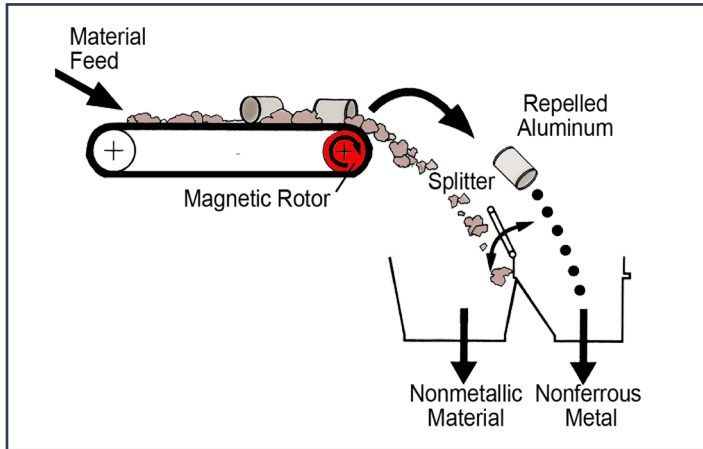

**9100 Concentric Model Sizes**  
**Magnetic Pulley Diameter:** 7"  
**Belt Width:** up to 48"  
**Rotor Speed:** up to 3000 rpm

## Eddy Current Concentric Design Magnetic Field & Shell Design

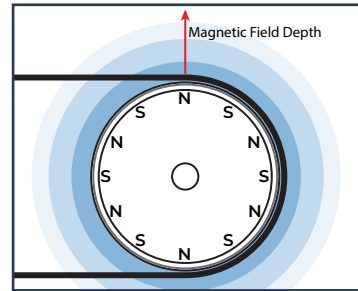

High frequency magnetic pole changes & high magnetic field strength provide superior product separation

**Note:** Depth of magnetic field is relative to the size of magnets inside the rotor. For example the 9500 Model has a larger/deeper field in comparison to the 9100.

## Triple Layer Shell Design

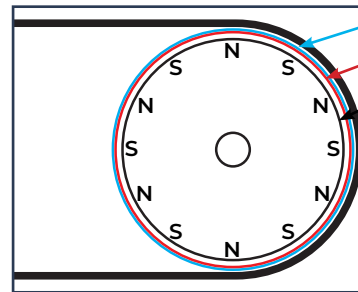

Ceramic Tile Shell Cover  
 Fiberglass Wear Shell  
 Heavy-Duty Stainless Steel Rotor Cover

This design provides maximum rotor protection that gives the equipment longer life, lower maintenance and repair costs and simplifies maintenance of the equipment.

## More Dings Company Magnetic Separation Equipment

### Severe Duty Overhead Self-Cleaning Electromagnet

"Durabelt" Stainless steel pads and cleats

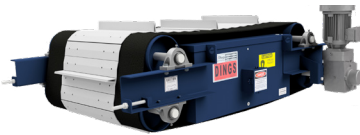

### Magnetic Head Pulley

Available in 3 different strength series



### Deep Drum Magnet

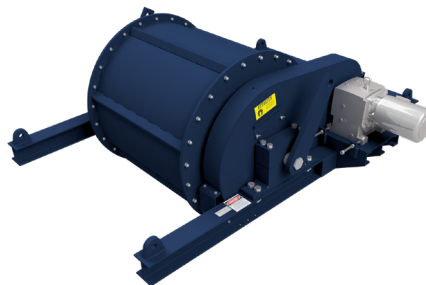

### Overhead Self-Cleaning Electromagnet

20-year warranty on coil burnout



### MRF (Material Recovery Facility) Overhead Self-Cleaning Electromagnet

3" high cleats



# Engineering Driven - Customer Service Focused



Dings Company Magnetic Group engineering and sales staff work together from our Milwaukee, WI factory to provide outstanding customer service from experts in magnetic separation. We listen to our customers to gain an understanding of their needs and apply our experience in their trade to provide magnetic separation equipment that is sized and positioned for the best possible performance in their specific application.