

Eddy Current Separator: Concentric 9500 Model

Engineered for High
Volume Through-Put

- ◇ Triple layer shell design protects valuable components
- ◇ Stainless-steel interior rotor shell around high strength rare earth magnets
- ◇ Polyurethane or nitrile wear resistant belt.
- ◇ Belt motor moves with take-up assembly for easy tracking and adjustment
- ◇ Oversized, high speed rotor bearings & shaft & a heavy-duty drive package

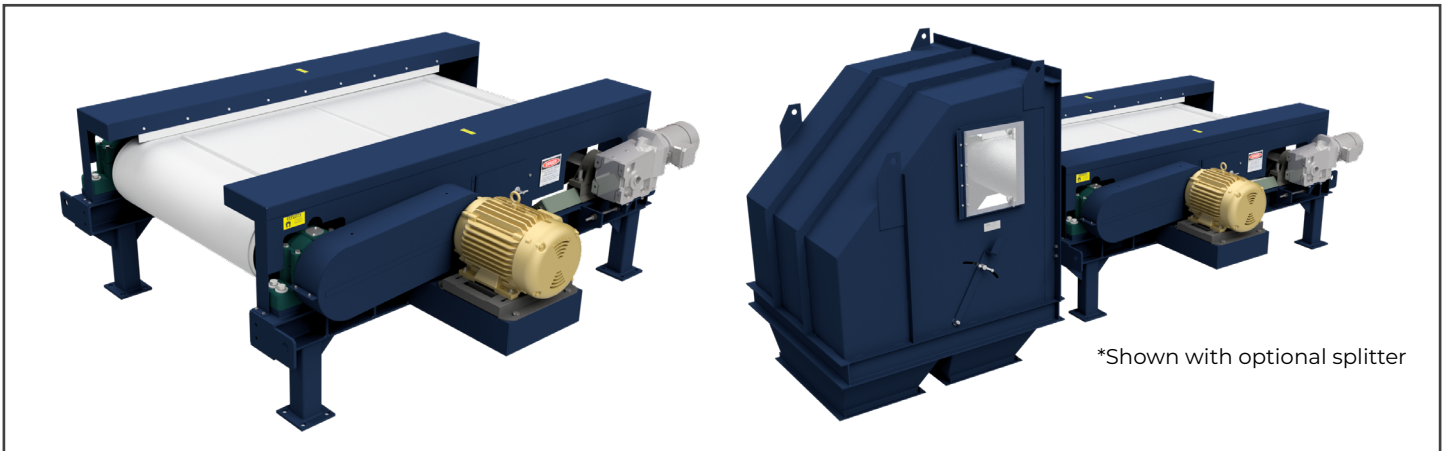

Eddy Current Separators

An Eddy Current Separator is designed to recover non-ferrous metal from non-metallic material such as commingled recyclables, plastics, glass, material processed at composting or waste-to-energy facilities, auto shredder residue, and various other industries. Our Eddy Current Separators provide significant savings on labor costs by reducing the man hours required for manual sorting. They are engineered for dirty, dusty and severe outdoor surroundings found at many job sites. The permanent rare earth magnets used in our Eddy Current Separators provide larger and deeper magnetic fields that are well-suited for industrial applications. These expanded magnetic fields also tolerate deeper burdens than the competition. Dings' renowned customer service and support is what separate us from the rest.

Eddy Current Separation Operation

When a piece of non-ferrous metal such as aluminum, passes over the separator, the magnets inside the rotor rotate past the aluminum at high speed. This forms eddy currents in the aluminum, creating a magnetic field inside the piece of aluminum. The polarity of that magnetic field is the same as the rotating magnet, causing the aluminum to be repelled away from the magnet. This

repulsion makes the trajectory of the aluminum greater than that of the nonmetallic material, allowing the two material streams to be separated.

Dings Eddy Current 9500 Concentric Model

Ideal for separating bigger pieces of non-ferrous metal and high throughput product streams. The 9500's concentric design has a triple layered shell consisting of an outer layer of ceramic tile and fiberglass around heavy duty stainless steel inner shell to protect the magnetic rotor assembly. This design lowers maintenance and replacement costs. The 9500 is manufactured with heavy duty structural steel I-beam frame and support structure, oversized shafts and bearings, and a heavy duty drive package.

- ◇ Generate income by recovering non-ferrous metals.
- ◇ Rare earth magnets provide high strength & long life.
- ◇ Deep magnetic field increases non-ferrous recovery.
- ◇ Optional integrated adjustable splitter with clear inspection doors provide access to the splitter.
- ◇ Save on costs of manual sorting.
- ◇ Fits easily into your existing line.

9500 Eddy Current Concentric Model Operation

Ideal for separating aluminum cans and other non-fractional sized non-ferrous metal from a paper and plastic product streams. The 9500's larger magnetic rotor size allows for a heavier throughput over the smaller 9100 or eccentric models.

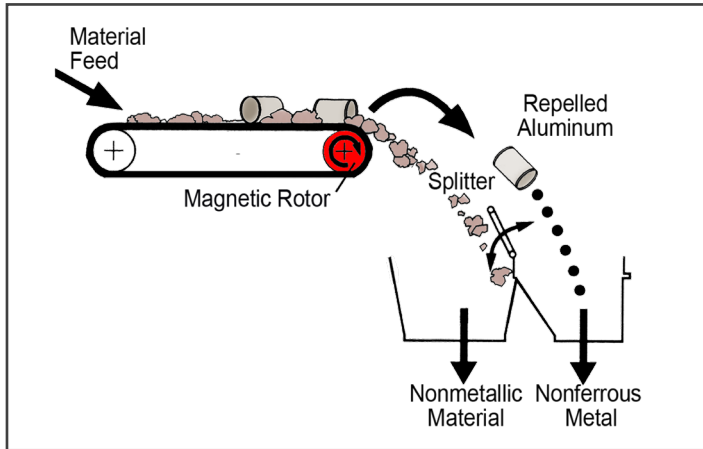

9500 Concentric Model Sizes

Magnetic Pulley Diameter: 13"
Belt Width: up to 72"
Rotor Speed: up to 1500 rpm

Eddy Current Concentric Design Magnetic Field & Shell Design

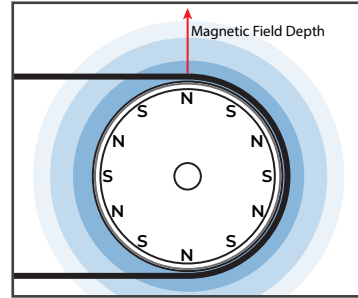

High frequency magnetic pole changes & high magnetic field strength provide superior product separation

Note: Depth of magnetic field is relative to the size of magnets inside the rotor. For example the 9500 Model has a larger/deeper field in comparison to the 9100.

Triple Layer Shell Design

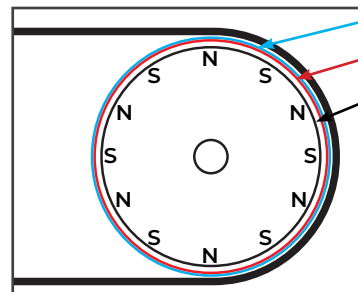

This design provides maximum rotor protection that gives the equipment longer life, lower maintenance and repair costs and simplifies maintenance of the equipment.

More Dings Company Magnetic Separation Equipment

Severe Duty Overhead Self-Cleaning Electromagnet

"Durabelt" Stainless steel pads and cleats

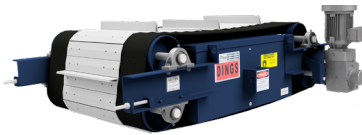

Overhead Self-Cleaning Electromagnet

20-year warranty on coil burnout



Deep Drum Magnet



Magnetic Head Pulley

Available in 3 different strength series

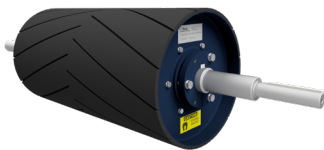

MRF (Material Recovery Facility) Overhead Self-Cleaning Electromagnet

3" high cleats



Engineering Driven - Customer Service Focused



Powerful Magnetic Products Since 1899

Dings Company Magnetic Group engineering and sales staff work together from our Milwaukee, WI factory to provide outstanding customer service from experts in magnetic separation. We listen to our customers to gain an understanding of their needs and apply our experience in their trade to provide magnetic separation equipment that is sized and positioned for the best possible performance in their specific application.