

## Deep Draw Drum:

- ◇ Designed with Ceramic VIII magnetic material encapsulated in stainless steel.
- ◇ Drum can be fed at any position with an adjustable internal magnet assembly
- ◇ Replaceable heavy duty manganese cover extends drum life
- ◇ Lateral or radial pole designs
- ◇ Magnetic adjusting arm rotates the magnet clockwise or counterclockwise
- ◇ Drum sized more efficiently for significant cost savings

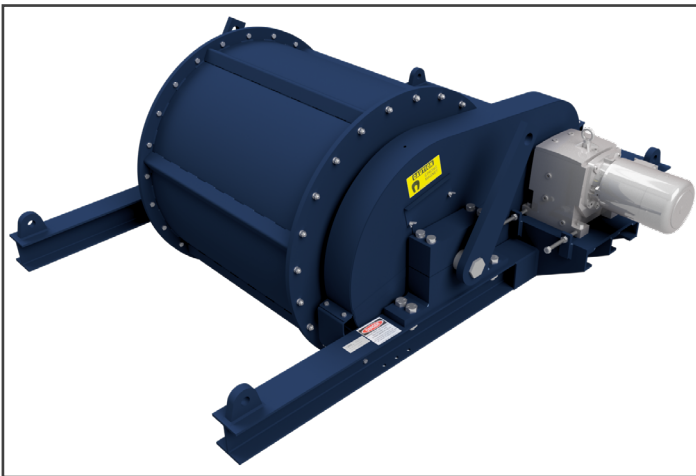

**Dings Deep Draw Drums** are specially designed for heavy duty, high-volume ferrous recovery. This large and powerful magnetic drum has a nonmagnetic outer shell that is driven around a fixed magnet. Ferrous metal is magnetically drawn out of the material feed, held against the rotating shell, and then released at the discharge point. Our Deep Draw Drum has the rugged construction needed for separating ferrous metal from the material stream in shredded cars, scrap metals, municipal solid waste, wood waste, slag, recycling crushed ore, ash at mass burn-out plants, and more. The Deep Draw Drum can be fed at multiple positions since the internal magnet assembly is adjustable.

The Dings Deep Draw Drum's permanent magnet design outperforms electric-powered models in a number of important ways, it always operates at top efficiency and maintains a constant magnetic strength throughout the day.

## Dings Flux Control (DFC) Circuit

Dings Flux Control (DFC) Circuit design eliminates internal leakage between magnetic poles and improves separating performance. Other 'conventional' magnetic circuits contain air or filler material between the magnetic poles; this allows flux (magnetism) to escape (leak out) and be wasted. In Dings DFC design - blocking magnets are strategically positioned in the spaces between the magnetic poles. These redirect the flux outward, into your product, converting the wasted flux into working force - making the magnet more efficient.

## Dings DFC Design improves the overall performance of the magnet in 3 ways

- ◇ The magnetic field is stronger
- ◇ The magnetic field extends deeper
- ◇ The magnetic field pattern is more uniform



On Magnetism  
for all Permanent  
Magnets

Conventional Magnetic Circuit  
With "filler" between the poles

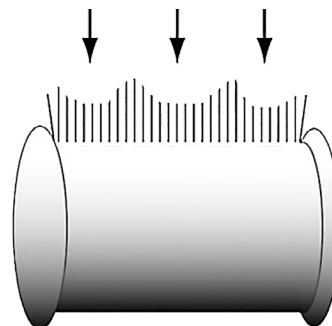

leakage

Dings Magnetic Circuit  
with blocking magnets  
between the poles

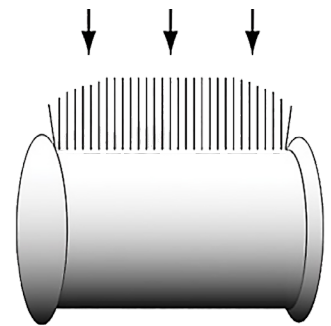

No leakage

# Feed Arrangements

Dings Deep Draw Drum can be fed in any position. After mounting, the magnet arc is adjusted to match the feed location. Feed position can affect the purity of recovered ferrous metal.

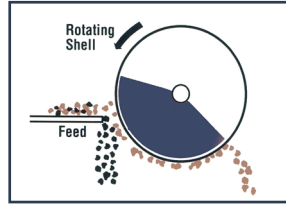

## Down-and-Under

This arrangement has the shortest and most direct transfer area for the ferrous.

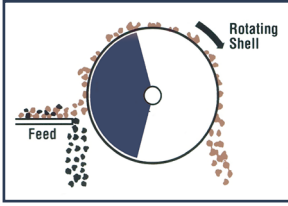

## Up-and-Over

Ferrous is lifted out of the burden and carried up and over the magnet while the nonferrous material drops off the feeder.

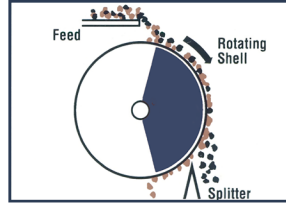

## Top Feed

The top feed arrangement is used with weakly magnetic ferrous or nonferrous pieces too large to pass through a reasonable gap setting.

**Feed at 9 o' clock position**

**Feed at 8 o' clock position**

**Feed at 12 o' clock position**

**Feed at 8 or 12 o' clock position**

**Standard and Extended Arc Radial Pole Drums**

Gap	6"	8"	10"	12"	14"	16"
Drum Dia.	24"	30"	36"	42"	48"	60"

Gap	4-5"	6-7"	8-9"	10-11"	12-13"	14-15"
Drum Dia.	24"	30"	36"	42"	48"	60"

Burden Depth	4"	5"	6"	8"	10"	12"
Drum Dia.	24"	30"	36"	42"	48"	60"

**Lateral Pole Drum**

Gap or Burden	2"	4"	6"
Drum Dia.	24"	30"	36"

## More Dings Company Magnetic Separation Equipment

**Overhead Self-Cleaning Electromagnet**  
20 year warranty on coil burnout



**Magnetic Head Pulley**  
Available in 3 different strength series



**Eddy Current Separator**  
Separate non-ferrous metal

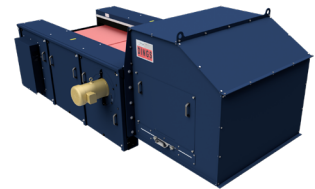

# Engineering Driven - Customer Service Focused

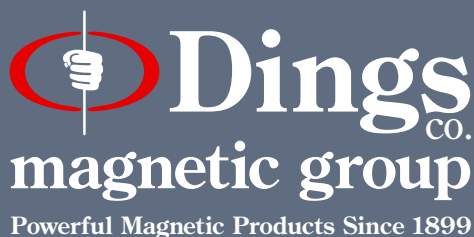

Dings Company Magnetic Group engineering and sales staff work together from our Milwaukee, WI factory to provide outstanding customer service from experts in magnetic separation. We listen to our customers to gain an understanding of their needs and apply our experience in their trade to provide magnetic separation equipment that is sized and positioned for the best possible performance in their specific application.