

# Installation and Maintenance Manual For

## **Dings Stationary Electro Overhead Magnets**



## Table of Contents

General Information .....	1
Installation Procedures	
Unpacking and Handling .....	2
Magnet Storage .....	3
Magnet Installation .....	4
Electrical Connections .....	7
Rectifier Over Current Protection.....	8
Maintenance .....	10
Electrical Troubleshooting .....	12
Print of Magnet .....	17
Print of Rectifier .....	17

## General Information

### **Magnet**

**Dings Model:**

**Dings Part Number:**

**Dings Serial Number:**

**Gallons of Oil in Magnet:**

### **Rectifier**

**Dings Model:**

**Dings Part Number:**

### **Warnings:**

This Dings magnet emits a powerful magnetic field when energized. The magnet must be positioned within an inaccessible or guarded area so that no contact can be made with the magnet while it is in operation.

The surface of the magnet box may reach temperatures of up to 230°F (110°C) while operating. Take care not to touch magnet surface and allow sufficient cooling time before handling.

Before performing maintenance, the magnet must be de-energized and allowed to cool for at least 6 hours. Lock out/tag out electrical supplies to prevent unexpected movement or magnetization during maintenance.

The magnet box is filled with transformer oil to cool the magnet during operation. Inspect oil level and quality regularly to prevent damage to magnet components.

### **CAUTION: STRONG MAGNET**

Strong magnetic field may have and affect on pacemakers and other electrical devices. Please contact the device manufacturer for further information.

## Unpacking and Handling

Upon receiving, check all packaged material for shortage of parts and possible damage. Report shortages and damage to the carrier who delivered shipment. The magnet was shipped fully assembled, ready for operation. Electrical connection is required to a suitable source of direct current such as a rectifier.

### Magnet

This Dings electromagnet was shipped using a pallet or 4" x 6" wooden beams as supports under the two sides of the magnet. After unloading, the magnet should never be placed directly on the ground. Rather, wood beams or some other means of support should be placed beneath the two sides of the magnet box to raise the magnet and belt above the ground.

The magnet should always be moved using the sling assembly provided. Never use a forklift or other device to lift the magnet from the bottom.

The magnet should be stored indoors prior to installation.

### Rectifier

The rectifier is a sensitive piece of electrical equipment. It has been shipped on a separate pallet to protect it during shipment. Take care not to drop or shake this equipment during handling.

The rectifier may be left strapped to the pallet while being moved. If it has been removed from the pallet, make sure it is securely fastened to forklifts or winches for moving.

The rectifier should be stored indoors prior to installation.

## Recommended Storage of Overhead Magnets

- 1) It is essential to keep moisture out of magnet cooling oil.
- 2) The following precautionary procedures are recommended:
  - a) Store magnet indoors in a low humidity, even temperature environment if possible.
  - b) Keep water and any other form of moisture away from the magnet while in storage.
- 3) This is a procedure for indoor storage only. Outdoor storage is definitely not advised and will null and void our warranty on the magnet assembly.
- 4) Rectifiers:
  - a) It is mandatory that the rectifier be stored indoors away from water and moisture.
  - b) It is recommended that the rectifier be put in a plastic, tightly sealed cover or bag to prevent moisture from getting into the rectifier if it's stored in an unheated building.
  - c) If possible, rectifier should be stored in an even temperature environment.

## MAGNET INSTALLATION

An electro overhead magnet is built in 2 types: Inline and Crossbelt. An Inline type is installed over a conveyor head pulley so that the single turnbuckle runs parallel to the travel direction of material falling off the conveyor. The head pulley must be made from non-magnetic material. A Crossbelt type is installed over a conveyor so that the single turnbuckle side of the magnet is at a right angle to the travel direction of the material on the conveyor.

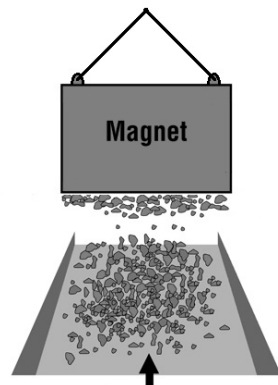

Crossbelt Suspension

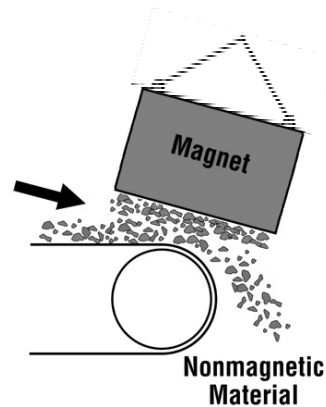

Inline Suspension

Magnetic performance may be affected by magnetic material in the field. This includes such items as I-beams, metal supports, hoppers, or splitters. These and other ferrous objects need to be kept out of the magnetic zone. Refer to the shaded area in the figure on page 5 for the dimensions of the magnetic zone.

## MAGNET INSTALLATION Continued

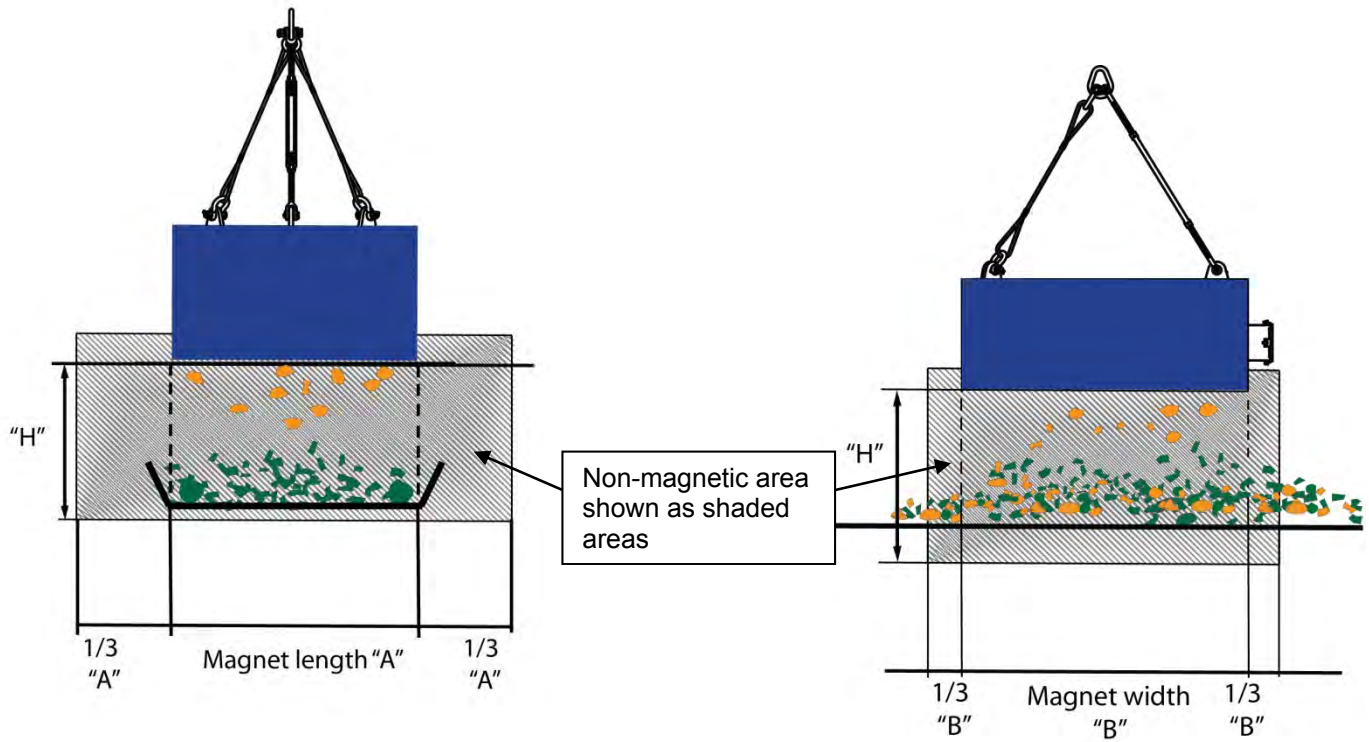

Model	"A"	"B"	"H"
22	30"	36"	20"
33	36"	42"	24"
44	42"	48"	28"
55	48"	54"	32"
66	54"	60"	36"
77	60"	66"	40"
88	66"	72"	44"
99	72"	78"	48"

\*For a "T" magnet model, switch dimensions "A" and "B"

Suspension height is critical to the performance of the magnet. This distance is measured from the bottom of the magnet face to the surface of the material handling belt.

The recommended suspension height is related to properties of the conveyor system and burden being processed. Assistance in determining the recommended suspension height is available by contacting the factory. To best determine this height, information including belt width, belt speed, troughing angle, burden bulk density, burden depth, maximum lump size, magnet orientation and model (if known) is required (see <http://www.dingsmagnets.com/magnet-literature/Overhead-Magnet-Application-Data.pdf> for a copy of the application data sheet).

If the magnet is suspended on an incline, ensure that the pressure relief (breather) valve is located on the high side of the magnet. Failure to locate the breather valve on the high side of the magnet may result in oil seepage from the valve. The location of the breather valve is easily changed between two possible positions on the top of the magnet.

## RECTIFIER INSTALLATION

If a rectifier was supplied with the electromagnet, mount the rectifier in a level position. Use only the mounting holes provided. Install the rectifier in a location suited to its NEMA rating. Do not install the rectifier near heat generating equipment or in direct sunlight.



## Electrical Connections

Electro Overhead Magnets operate on direct current. The DC connections to the magnet are made in the terminal box located on one side of the magnet. Polarity is not important. The DC current is supplied by a rectifier. Do not ground the DC circuit or the magnet will be damaged.

Switching should be done on the input (AC) side of the rectifier. This will avoid excessive arcing and high inductive voltages which develop when a magnet coil circuit is opened.

Wiring should be in accordance with prevailing local and national electric codes. Wire size should be based on the nameplate wattage. As magnet coil warms, the wattage will decrease.

Voltage of magnet terminals should be within  $\pm 5\%$  of nameplate voltage. If the unit is a self cleaning magnet, check that the motor wiring is correct for all the power supplied. Make sure the nuts on the motor wiring tabs are all tight. When operating properly, the magnet will run hot. The magnet coil is immersed in a special oil which allows it to operate at an extremely high magnetic intensity. Oil continuously circulates in and around all parts of the coil windings. This circulation allows even heat distribution for longer coil life. This heat is transferred to the magnet case for dissipation.

NOTE: Some models have a junction box mounted on the frame. This box is pre-wired to the terminal box on the magnet body. Connect DC power to the junction box as described previously.

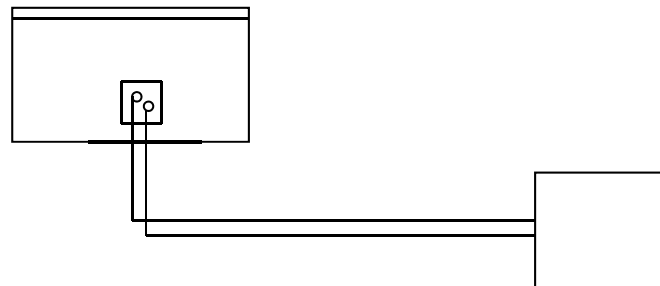

Connect to a DC Power Source  
(Polarity is non-essential)  
Voltage and watts appear  
on magnet nameplate.

## RECTIFIER INPUT OVER-CURRENT PROTECTION

All rectifiers contain a transformer. A transformer has all the same component parts as a motor, and like a motor, exhibit a current inrush when energized. This inrush current is dependent upon where in the sine wave the transformer was last turned off in relation to where in the sine wave the transformer is when you energize it. Although transformer current inrush could run up to 30 to 35 times full load current under a no load condition, it typically will be the same as a motor at about 6 to 8 times the full load current. For this reason it is important to use a dual element time delay type fuse, the same type of fuse you would use with a motor. If using circuit breakers, select a breaker with a time delay, again the same type you would use with a motor. If the time delay is not sufficient, you may experience “nuisance tripping”, a condition where the circuit breaker trips when energizing the transformer but when you try it again, it works fine.

### **Fuses**

Use a dual element time delay fuse or a circuit breaker with a time delay having a rating of 175 percent of the full load current to protect the input side of the rectifier. If 175% of full load amps does not correspond to a standard fuse size, select the next larger standard fuse size (but not exceeding 225%).

### **Circuit Breakers**

Use an inverse time circuit breaker with a maximum rating of 250% of the full load current. If 250% of full load amps does not correspond to a standard circuit breaker size, select the next larger size (but not exceeding 400%).

### **ETL Rectifiers**

A rectifier that carries the ETL Listing for the U.S. and Canada conforms to UL STD 508A and is certified to CSA STD C22.2 No. 14 & CSA STD C22.2 No. 73. For this reason, all ETL certified rectifiers include an inverse time circuit breaker sized to protect the rectifier from overcurrent conditions. The circuit breaker was selected based on the criteria provided above. This circuit breaker is also equip with a rotary handle disconnect which opens the circuit when the enclosure door is opened. Additional protection may be added to the supply lines in order to comply with local and national electric codes.

### **Caution:**

Always follow the latest edition of the National Electric Code and any other applicable codes for over-current protection of 600-volt class transformers to determine the proper over-current protection for rectifiers. One special consideration not listed in the above codes is to be careful of the type of fuse or circuit breaker used to protect the input side of the transformer.

**OVER-CURRENT SELECTION EXAMPLE:**

Model 33 Electro Magnet  
5 kW, NEMA 12 Rectifier

AC input: 460 VAC/3phase/60 Hz, 6.7 amps

**Time Delay Fuses**

$6.7 \text{ amps} \times 175\% = 11.73 \text{ amps}$  11.73 is a non-standard fuse size. The next standard fuse size is 12 amps. 12 amps is 179% of the full load amps, but is under the 225% maximum limit. USE A 12 AMP TIME DELAY FUSE.

**Circuit Breakers**

$6.7 \text{ amps} \times 250\% = 16.75 \text{ amps}$ . 16.75 is a non-standard circuit breaker size. The next standard circuit breaker size is 20 amps. 20 amps is 299% of full load amps, but under the 400% maximum limit. USE A 20 AMP INVERSE TIME CIRCUIT BREAKER.

## MAINTENANCE

### LUBRICATION SCHEDULE FOR OVERHEAD ELECTRO MAGNET

ITEM	QUANTITY		BRAND & GRADE	INTERVAL
<b>Transformer Type Cooling Oil – Gallons by Magnet Size</b>	<b>Size</b>	<b>Gallons of Oil</b>	Isovoltine 410 or equivalent	Check for volume every 3 months. Replace oil every 2-3 years**
	22	57		
	33	77		
	44	105		
	55	158		
	66	200		
	77	306		
	88	362		
	99	401		
	910	495		
	1000	918		

\*\*Note: The oil should be laboratory tested every 12 months for moisture, contaminants, and dielectric strength.

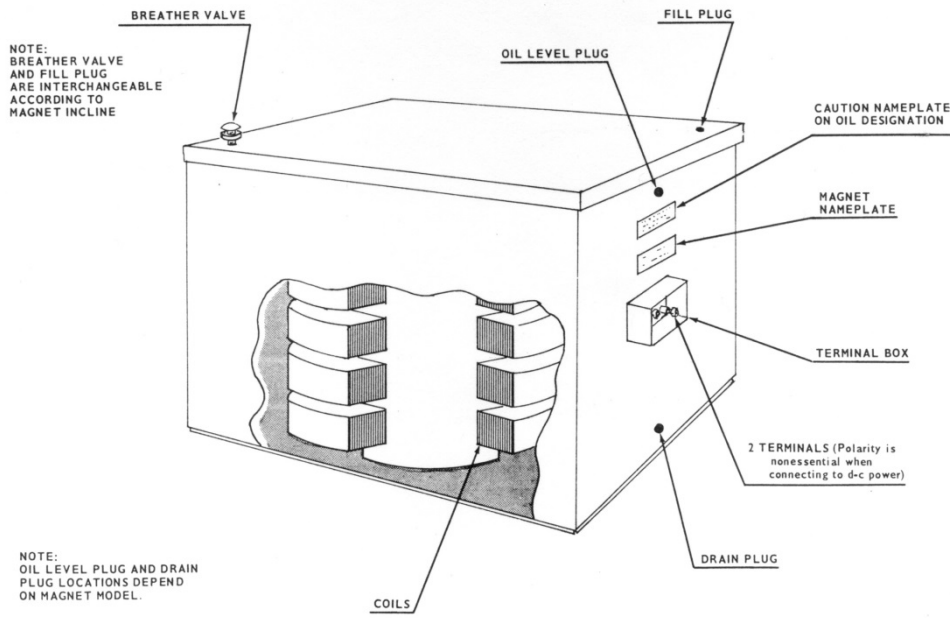

Periodic inspection and maintenance are required. Check magnet body for oil leaks. Check pressure relief valve (breather) on top of magnet. It should be free of dirt and obstructions. Oil seepage from breather is no cause for alarm. It may result from overfilling.

### OIL CHANGE OR REFILL

**CAUTION:** Allow oil to cool completely before servicing.

Oil level should appear at oil level plug hole when magnet is level. Oil should remain clear and free of contaminants. Sludge in oil will greatly reduce service life. If oil is turbid or cloudy, replace it. Do not mix new oil with old oil.

**USE ONLY THE SPECIFIC COOLING OIL** designated on the caution nameplate located on the side of the magnet. Read this nameplate. The electromagnet contains special high temperature cooling oil. The use of any different oil can be a fire hazard.

This magnet was originally filled at the Dings factory with the type of oil marked on the caution nameplate. This oil is safe for use at the high temperature at which this magnet normally operates. Do not add any amount of any other oil or liquid.

To drain oil, remove drain plug in side of magnet body near bottom. Remove fill plug in top surface of magnet body. Drain and flush magnet clean using new oil (don't use old oil or cleaning solvent).

To refill, replace plug in drain hole. Remove oil level plug in side of magnet body near top. Place magnet in level position. Fill with oil to oil level plug hole. Reinstall oil level plug and reinstall oil fill plug. Note - seal plugs with Permatex No. 2 non-hardening. (Do not use silicone as it is not compatible with the oil and leaks will develop).

**GENERAL** – Periodically check hex head set screws and bearing bolts for tightness. Tighten if loose.

## ELECTRICAL TROUBLESHOOTING

Before starting, first follow this preliminary checklist:

1. Check all fuses and/or circuit breakers. For fuses, use a dual element time delay fuse with a maximum of 175% of the full load current to protect the input side of the rectifier. If 175% of full load amps does not correspond to a standard fuse size, select the next larger standard fuse size (but do not exceed 225%). For circuit breakers, use an inverse time circuit breaker with a maximum of 250% of full load current. If 250% does not correspond to a standard circuit breaker size, select the next larger standard circuit breaker size (but do not exceed 400% for 100 amps or less).
2. Check all wiring for loose or broken connections.
3. Visually inspect all internal rectifier components.
4. If equipped with a starter, check all overloads (bi-metallic components) to see if any have tripped. Wait several minutes before resetting.
5. If equipped with a starter, check to see if correct heaters for selected voltage are installed and that load does not exceed nameplate rating.
6. Do not ground the DC circuit supplying the magnet or damage will occur.

### WARNING

The following procedures should be performed by a qualified electrician. Extreme caution should be used as live electrical equipment will be tested. Before starting the testing procedure, turn off and lock-out any surrounding equipment that may pose a danger during testing. If the magnet is of the self-cleaning type, turn off and lock-out the power to the self-cleaning belt motor. The following instructions are for standard 480 VAC or 600 VAC, 3 phase, 60 Hz rectifiers. For special input voltages, consult factory.

### STEP 1

Disconnect the DC cable leads to the magnet AT THE RECTIFIER TERMINAL BLOCK inside the rectifier cabinet. Turn on the power to the rectifier. Measure the AC input voltage to the rectifier at the terminal block.

1st Reading Phase 1 to Phase 2 Volts:

2nd Reading Phase 2 to Phase 3 Volts:

3rd Reading Phase 3 to Phase 1 Volts:

If all three voltage readings are within the following tolerances, the power supplying the rectifier is OK. Go to Step 2.

480 VAC  $\pm$  5% for 480 VAC input rated rectifiers.

600 VAC  $\pm$  5% for 600 VAC input rated rectifiers.

If one or more of the voltage readings are out of tolerance, the power supplied to the rectifier is incorrect and must be corrected.

**STEP 2**

Turn off and lock-out the power to the rectifier. Disconnect the three leads from the transformer to the diode assembly inside the rectifier cabinet. Turn on the power to the rectifier. Measure the AC voltage at the output of the transformer inside the rectifier cabinet.

1st Reading Phase 1 to Phase 2 Volts:

2nd Reading Phase 2 to Phase 3 Volts:

3rd Reading Phase 3 to Phase 1 Volts:

If all three voltage readings are  $85 \text{ VAC} \pm 5\%$  for 115 VDC output rated rectifiers or  $170 \text{ VAC} \pm 5\%$  for 230 VDC output rated rectifiers, the transformer is OK. Go to Step 3. If one or more of the voltage readings are out of tolerance, replace the transformer or the entire rectifier.

**STEP 3**

Turn off and lock-out the power to the rectifier. Reconnect the three leads from the transformer to the diode assembly at the transformer output lugs inside the rectifier cabinet. Disconnect the two rectifier output leads to the magnet at the terminal block inside the rectifier cabinet marked "+" and "-". Turn on the power to the rectifier. Measure the DC output voltage of the rectifier at the terminal block inside the rectifier cabinet marked "+" and "-".

VOLTS:

If the reading is  $115 \text{ VDC} \pm 5\%$  for 115 VDC output rated rectifiers or  $230 \text{ VDC} \pm 5\%$  for 230 VDC output rated rectifiers, the rectifier is OK. Go to Step 4. If the voltage reading is out of tolerance, replace the diode assembly.

**STEP 4**

Turn off and lock-out the power to the rectifier. Reconnect the two rectifier output leads to the magnet at the terminal block inside the rectifier cabinet. Turn on the power to the rectifier. Measure the DC voltage at the magnet box terminals on the magnet, not at the secondary terminal box on the magnet if so equipped.

VOLTS:

If the reading is  $115 \text{ VDC} \pm 5\%$  for 115 VDC output rated rectifiers or  $230 \text{ VDC} \pm 5\%$  for 230 VDC output rated rectifiers, the leads and terminal blocks between the rectifier and the magnet box terminals are OK. Go to Step 5. If the voltage reading is out of tolerance, replace or repair the leads between the rectifier and the magnet, as leads may be damaged, loose or undersized. Use caution not to rotate the studs in the magnet box terminals or the internal connections may be damaged.

**STEP 5**

Turn off and lock-out the power to the rectifier. Disconnect the two leads from the rectifier to the magnet at the magnet box terminals, using caution not to rotate the studs in the feed through terminals as the internal connections may be damaged. The magnet must be cold for the following tests. Referring to the equation below, use the watts and the volts from the nameplate on the magnet, square the nameplate DC volts (115 VDC or 230 VDC) and divide by the nameplate watts to get the target ohm reading. Measure the ohms between the two magnet box terminals.

$$\text{Target OHMS} = \frac{\text{Nameplate DC VOLTS}^2}{\text{Nameplate WATTS}} :$$

OHMS:

NOTE: There is no polarity for the magnet terminal posts. Either lead can be connected to either terminal.

If the ohm reading is within  $\pm 10\%$  of the target ohm reading, go to Step 6. If the ohm reading is out of tolerance or infinity, consult the factory, supplying all of the above readings that were taken.

**STEP 6**

Measure the ohm reading between one of the magnet box terminals and the magnet housing, (The preferred measuring instrument is a megger.)

OHMS:

If the reading is one megohm (1,000,000 ohms) or larger, the magnet is OK. If the megger ohm reading is out of tolerance, consult the factory, supplying all of the above readings that were taken.

If it has been determined that the rectifier and the magnetic separator are electrically sound and the performance of the separator is still in doubt, contact the factory for further assistance. There are many factors which can affect the ability of a separator to attract metal.

**SIGNIFICANCE OF ELECTRICAL READINGS:**

Low DC Volts	Magnet will be weak
Low Ohms (resistance)	Possible shorted turns in coils
High Ohms	Possible poor connection or open coil circuit
Low DC Amps	Possible poor connection or open coil circuit
High DC Amps	Possible shorted turns in coils



Megger Reading Less Than 1 Megohm      One or more coils are grounded, poor insulation or transformer oil is contaminated with water

Send readings to Dings Company for evaluation and recommendations:

Phone:      414-672-7830

Fax:      414-672-5354

E Mail:      [magnets@dingsco.com](mailto:magnets@dingsco.com)

**When changing the diode assembly, it is highly recommended that the surge suppressor be changed as well.**

### Standard Rectifier Panel Layout and Wiring Schematic

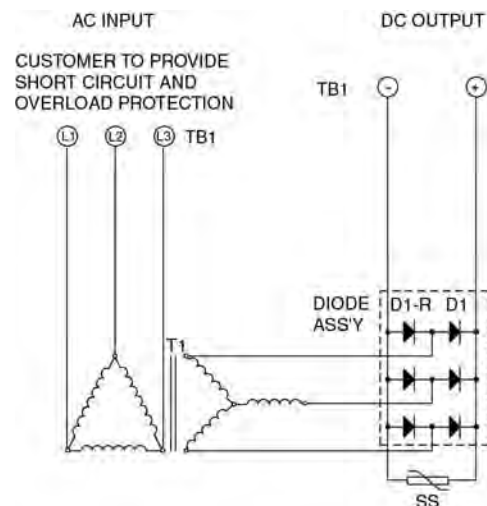
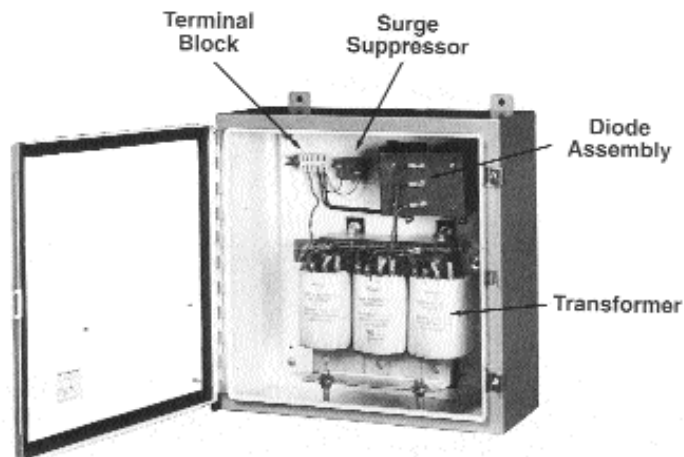

**ETL Rectifier Panel Layout and Wiring Schematic**

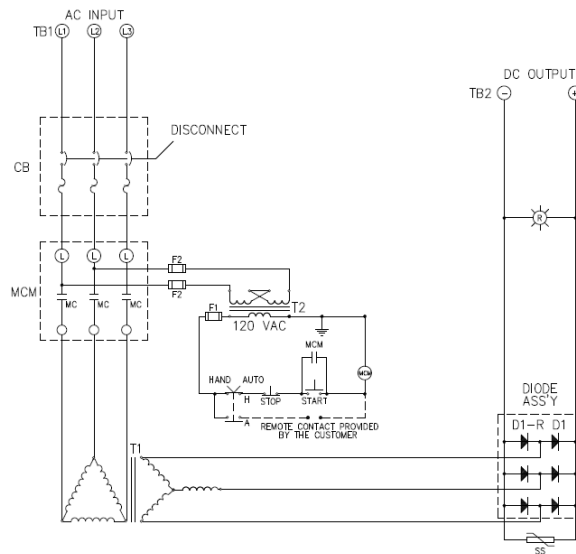
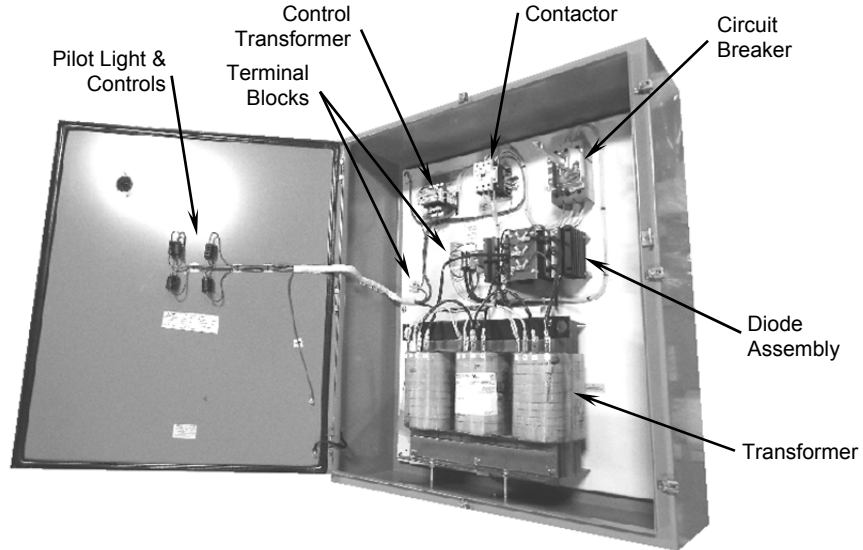

*Generic panels and schematics are pictured above and may be different from the purchased rectifier. Refer to the schematic diagram included with the rectifier or contact Factory for a replacement.*